

制动单元 Braking Unit

产品简述 (Product Profile)

DBU系列制动单元的作用是将马达在减速的过程中产生的再生能量，以热能的形式消耗在制动电阻上，从而改善变频器的制动性能及缩短变频器的制动时间。

The function of the DBU braking unit is to divert into a braking resistor the regenerative energy produced in the process of decelerating the motor, converting that energy into heat. Regenerative energy flows from the motor into the inverter DC Bus, manifested as increased bus voltage. The advantage gained using the DBU is improved braking performance and shorter deceleration time of the load.



产品特点 (Product Features)

- 安全性**：具有IGBT短路击穿脱扣功能，可以有效地防止因IGBT击穿，电阻器长时间过负荷运行而引起的火险隐患。
- 广泛性**：特殊设计可以使用普通电阻，不必选择无感电阻。斩波电压DC630V-DC760V可调，适用于各种中低压变频器（特殊设计可达1200V）。
- 经济性**：性价比高，品质可与同类进口产品相媲美，价格较低，是变频器刹车、制动回路中经济、实用的配套产品。
- 可并联使用**：采用书本型设计，可无间隙并联安装，推荐最多3台并联使用。

1.Safety: The tripping function against IGBT short circuit breakdown can avoid the fire caused by IGBT short circuit breakdown of resistor after long-time overload run.

2.Wide Compatibility: Its special design makes it compatible with general resistors rather than non-inductive ones.Its adjustable chopper voltage DC630V-DC760V is applicable to various low-voltage inverters.

3.Economical Feature: Its cost performance is high.Its quality is parallel to similar type of imported products but its price is low.It is considered the most cost-effective and practical auxiliary product for braking circuits of inverters.

4.Adaptable to connections in parallel: The book-shape design is adopted and Braking Units can be installed in parallel connection with zero clearance. It is recommended that up to 3 units be connected in parallel.

产品尺寸图 (Product Size)



图 A Picture A



图 B Picture B

选型表 (Selection Table)

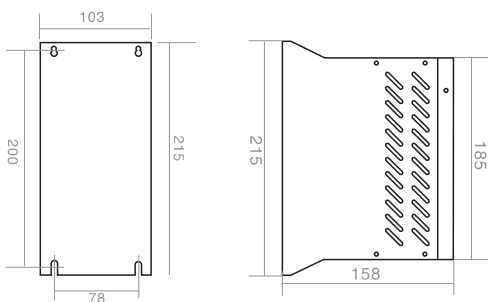
规格 Type	外型图 Size picture	额定 制动电流 Rated braking current	最大 制动电流 Max. braking current	斩波电压 Chopper voltage	安装孔 尺寸 Mounting hole size	端子 Terminal	重量 Weight (kg)	配线 Cable (mm)
DBU-2015	A	15A	50A	DC380V±5V	Φ6	M4	2.3	4-6
DBU-2022C		25A	75A	DC380V±5V	Φ6	M4	2.3	4-6
DBU-2030C		30A	90A	DC380V±5V	Φ6	M4	2.3	6-8
DBU-4030D		15A	50A	DC630/DC660/DC690V DC730V/DC760V±10V	Φ6	M4	2.3	4-6
DBU-4045C		25A	75A	DC630/DC660/DC690V DC730V/DC760V±10V	Φ6	M4	2.3	4-6
DBU-4110B	B	60A	200A	DC630/DC660/DC690V DC730V/DC760V±10V	Φ8	M8	13.2	16-36
DBU-4220B		85A	300A	DC630/DC660/DC690V DC730V/DC760V±10V	Φ8	M8	13.2	16-36
DBU-4300		120A	500A	DC630/DC660/DC690V DC730V/DC760V±10V	Φ8	M8	13.2	25-50
DBU-6220		85A	300A	DC1000V/DC1050V/DC1100V DC1150V/DC1200V±20V	Φ8	M8	13.2	16-36
DBU-11220		85A	300A	DC1750V/DC1800V/DC1850V DC1900V/DC1950V±40V	Φ8	M8	21	16-36

其他技术参数要求，请垂询我司业务 For other technical parameters & requirements, please contact our company's salespeople.

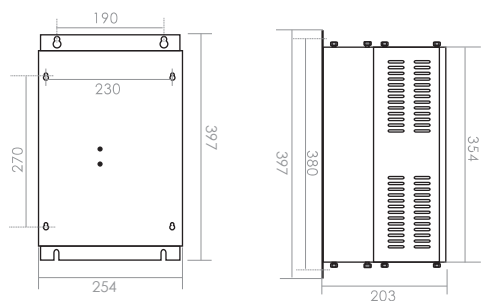
成品识别 (Product Identification Code)

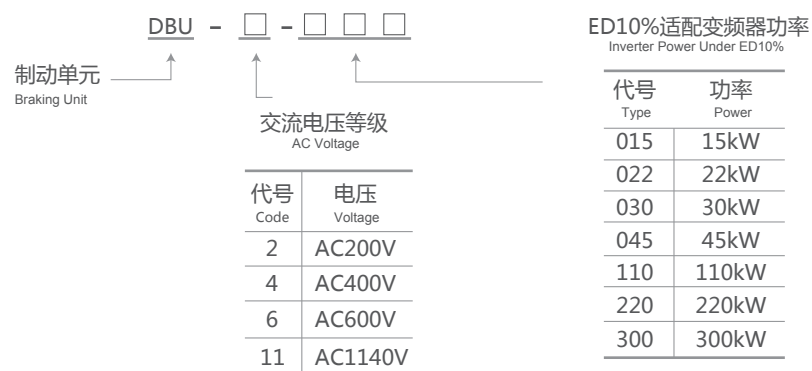

制动单元 Braking Unit

■ ED = 10%, 起始斩波电压VDC = 760V (ED = 10% , braking activation voltage = 760 VDC)
适用普通机械、10层以下电梯, 起重机大小车选用。(Apply to common machine and the elevator (less than 10 storeys), crane trolley)

变频器功率(kW) Inverter power	制动单元型号 DBU type	制动单元数量 Quantity of DBU	电阻配置 Resistor	电阻数量 Quantity of resistors	制动转矩(10%ED) Braking torque
0.4	DBU-4030D	1	70W 750Ω	1	230
0.75	DBU-4030D	1	70W 750Ω	1	130
1.5	DBU-4030D	1	260W 400Ω	1	125
2.2	DBU-4030D	1	260W 250Ω	1	135
3.7	DBU-4030D	1	390W 150Ω	1	135
5.5	DBU-4030D	1	520W 100Ω	1	135
7.5	DBU-4030D	1	780W 75Ω	1	130
11	DBU-4030D	1	1040W 50Ω	1	135
15	DBU-4030D	1	1560W 40Ω	1	125
18.5	DBU-4030D	1	4800W 32Ω	1	125
22	DBU-4030D	1	4800W 27.2Ω	1	125
30	DBU-4030D	1	6000W 20Ω	1	125
37	DBU-4045C	1	9600W 16Ω	1	125
45	DBU-4045C	1	9600W 13.6Ω	1	125
55	DBU-4030D	2	6000W 20Ω	2	135
75	DBU-4045C	2	9600W 13.6Ω	2	145
110	DBU-4030D	3	9600W 20Ω	3	100
110	DBU-4110B	1	30kW 6.8Ω	1	100
160	DBU-4220B	1	40kW 3.4Ω	1	140
220	DBU-4220B	1	60kW 3.2Ω	1	110
300	DBU-4300	1	80kW 2.5Ω	1	110
600	DBU-4300	2	90kW 2.5Ω	2	130

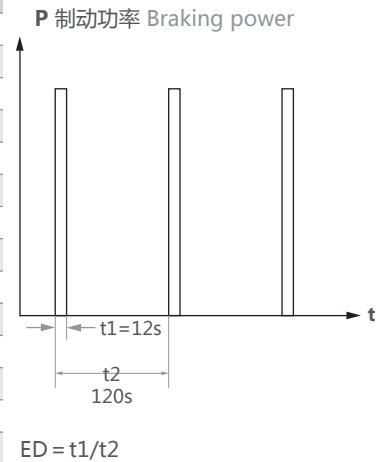

■ ED = 20%, 起始斩波电压VDC = 760V (ED = 20% , braking activation voltage = 760 VDC)
适用中等机械设备、20层以下电梯选用。(Apply to medium mechanical equipment and elevator (less than 20 storeys))

变频器功率(kW) Inverter power	制动单元型号 DBU type	制动单元数量 Quantity of DBU	电阻配置 Resistor	电阻数量 Quantity of resistors	制动转矩(10%ED) Braking Torque
0.4	DBU-4030D	1	140W 750Ω	1	230
0.75	DBU-4030D	1	140W 700Ω	1	145
1.5	DBU-4030D	1	520W 350Ω	1	150
2.2	DBU-4030D	1	520W 230Ω	1	155
3.7	DBU-4030D	1	780W 140Ω	1	150
5.5	DBU-4030D	1	1040W 90Ω	1	155
7.5	DBU-4030D	1	1560W 70Ω	1	145
11	DBU-4030D	1	2kW 47Ω	1	150
15	DBU-4030D	1	3kW 34Ω	1	150
18.5	DBU-4030D	1	9600W 28Ω	1	150
22	DBU-4030D	1	9600W 24Ω	1	145
30	DBU-4045C	1	12kW 17Ω	1	150
37	DBU-4045C	1	20kW 16Ω	1	125
45	DBU-4030D	2	10kW 24Ω	2	145
55	DBU-4045C	2	12kW 18Ω	2	155
75	DBU-4045C	2	18kW 13.6Ω	2	150
110	DBU-4045C	3	15kW 16Ω	3	145
160	DBU-4220B	1	80kW 3.2Ω	1	150
220	DBU-4300	1	110kW 2.5Ω	1	150
300	DBU-4220B	2	80kW 3.5Ω	2	150
600	DBU-4300	3	100kW 2.6Ω	3	150

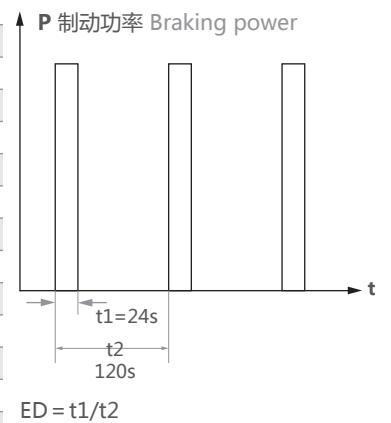

■ ED=40%,起始斩波电压VDC = 760V(ED = 40% , braking activation voltage = 760 VDC)
适用30层以上电梯, 轻型起重机主钩选用。(Apply to elevators(over 30 storeys), main hook of the light crane)

变频器功率(kW) Inverter power	制动单元型号 DBU type	制动单元数量 Quantity of DBU	电阻配置 Resistor	电阻数量 Quantity of resistors	制动转矩(10%ED) Braking torque
0.4	DBU-4030D	1	240W 750Ω	1	230
0.75	DBU-4030D	1	450W 550Ω	1	190
1.5	DBU-4030D	1	800W 275Ω	1	190
2.2	DBU-4030D	1	1.3kW 180Ω	1	135
3.7	DBU-4030D	1	2.2kW 110Ω	1	190
5.5	DBU-4030D	1	3.3kW 75Ω	1	190
7.5	DBU-4030D	1	4.5kW 55Ω	1	190
11	DBU-4030D	1	6.6kW 37Ω	1	190
15	DBU-4030D	1	9kW 27Ω	1	190
18.5	DBU-4045C	1	11kW 22Ω	1	190
22	DBU-4045C	1	13kW 18Ω	1	190
30	DBU-4030D	2	10kW 27Ω	2	190
37	DBU-4045C	2	11kW 22Ω	2	190
45	DBU-4045C	2	13.5kW 18Ω	2	190
55	DBU-4045C	3	12kW 22Ω	3	190
75	DBU-4045C	4	11kW 22Ω	4	190
110	DBU-4220B	1	66kW 3.7Ω	1	190
160	DBU-4220B	2	48kW 5Ω	2	190
220	DBU-4220B	2	66kW 3.7Ω	2	190
300	DBU-4300	2	90kW 2.7Ω	2	190
600	DBU-4300	4	90kW 2.7Ω	4	190

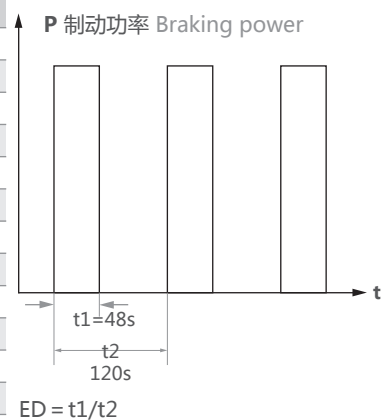

注：港口、码头货场起重设备处于高频率使用状态，其配置要按ED = 60%~80%选配，具体配置情况请与我公司联系。
Note: The yard lifting equipment of port and wharf is in a state of high frequency use, and its configurations are matched according to ED=60%~80%; for specific configurations, contact our company please.