

NCV7748

Automotive LIN Low-Side Relay Driver

The NCV7748 is an automotive eight channel low-side driver providing drive capability up to 0.75 A per channel. Output control is via a LIN bus with optimized LIN command set allowing high flexibility while still maintaining compliance to SAE J2602 LIN specification.

Each output driver includes an output clamp for inductive loads.

All output drivers have overcurrent detection implemented. Selected low side drivers (OUT4,8) offer additional reporting of faults for open load (or short to ground) and individual over temperature conditions which allows connection to a wiring harness outside of the module.

The NCV7748 is available in an SOIC14 package.

Features

OUTPUT DRIVERS

- Low-side Drivers, 8 Channels
 - ◆ OUT4 & OUT8 0.75 A, R_{DSon} 0.8 Ω (typ), 1.6 Ω (max)
 - ◆ OUT1–3 & OUT5–7 0.6 A, R_{DSon} 1.5 Ω (typ), 3.0 Ω (max)
- Low Quiescent Current in Sleep Mode
- Fault Reporting
- Global Over Temperature Detection and Shutdown
- Power-on Reset and Undervoltage Detection

LIN-Bus INTERFACE

- Integrated LIN Physical Layer Compliant to SAE J2602/LIN2.x
- Integrated State Machine for SAE J2602 Compliant LIN Protocol Handling and the LIN Message Decoding
- Virtual LIN Node Concept to Drive up to 32 Relays using One LIN Node Address with up to Four Slaves Devices
- Device Node Address (NAD) Selectable by External Resistor
- LIN Bus Short-circuit Protection to Supply and Ground
- Automatic Bit Rate Synchronization
- NCV Prefix for Automotive and Other Applications Requiring Unique Site and Control Change Requirements; AEC-Q100 Qualified and PPAP Capable
- These Devices are Pb-Free, Halogen Free/BFR Free and are RoHS Compliant

Typical Applications

- Power Distribution Box (PDB); Power Distribution Center (PDC)
- Body Junction Box (BJB); Engine Junction Box (EJB)
- Rear Junction Box (RJB); Body Electrical Center (BEC)
- Interior Electrical Center (IEC); Rear Electrical Center (REC)
- Underhood Electrical Center (UEC); Junction Box (JB)



ON Semiconductor®

www.onsemi.com

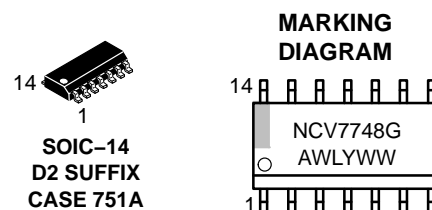

NCV7748 = Specific Device Code
A = Assembly Location
WL = Wafer Lot
Y = Year
WW = Work Week
G = Pb-Free Package

PIN CONNECTIONS

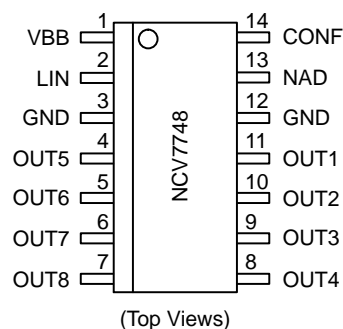

ORDERING INFORMATION

See detailed ordering and shipping information on page 29 of this data sheet.

NCV7748

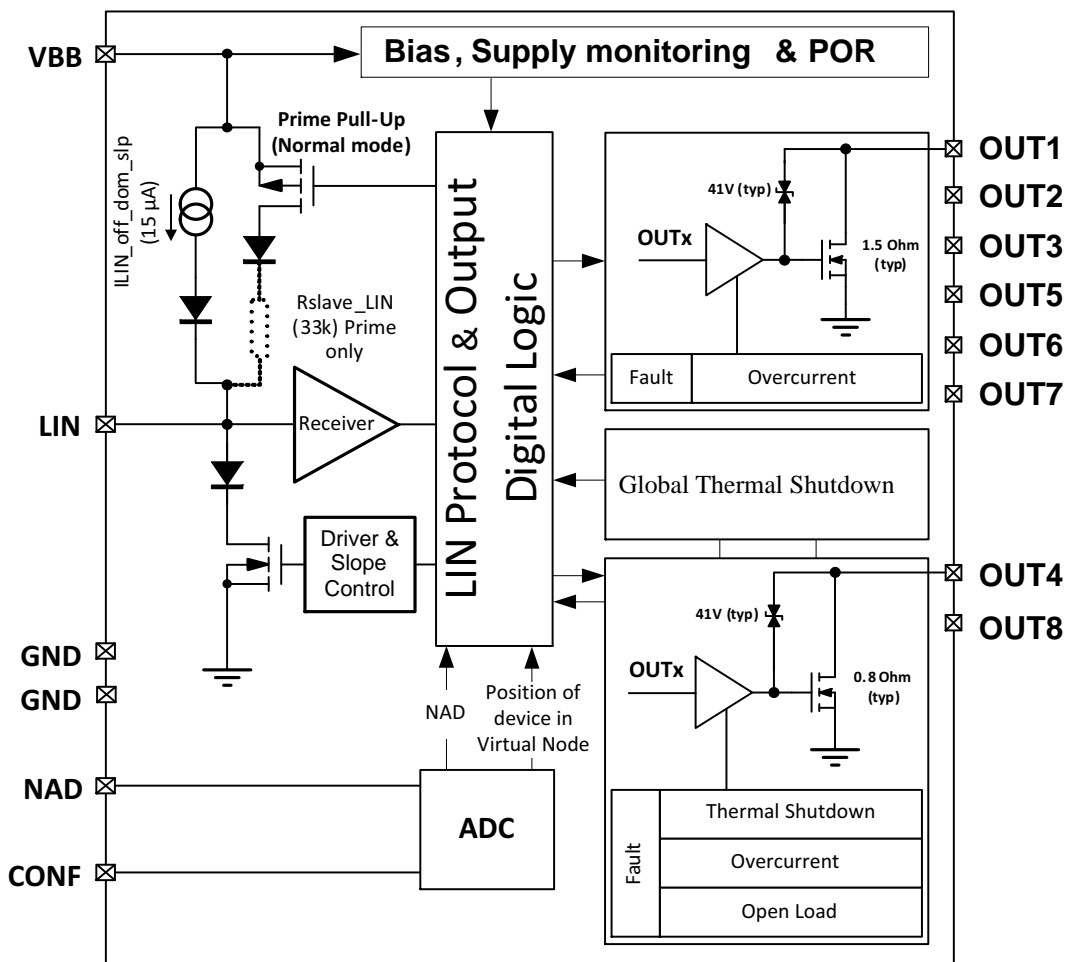

Figure 1. Block Diagram

NCV7748

Table 1. PIN FUNCTION DESCRIPTION, NCV7748

| Pin No. | Pin Name | Pin Type | Description |
|---------|--------------|------------------------|---|
| 1 | VBB | Battery supply input | Battery connection |
| 2 | LIN | LIN bus interface | LIN bus pin, low in dominant state |
| 3 | GND (Note 1) | Ground | Ground connection |
| 4 | OUT5 | LS driver | Channel 5 Low-side drive output, Ron = 1.5 Ω (typ) |
| 5 | OUT6 | LS driver | Channel 6 Low-side drive output, Ron = 1.5 Ω (typ) |
| 6 | OUT7 | LS driver | Channel 7 Low-side drive output, Ron = 1.5 Ω (typ) |
| 7 | OUT8 | LS driver | Channel 8 Low-side drive output, Ron = 0.8 Ω (typ) |
| 8 | OUT4 | LS driver | Channel 4 Low-side drive output, Ron = 0.8 Ω (typ) |
| 9 | OUT3 | LS driver | Channel 3 Low-side drive output, Ron = 1.5 Ω (typ) |
| 10 | OUT2 | LS driver | Channel 2 Low-side drive output, Ron = 1.5 Ω (typ) |
| 11 | OUT1 | LS driver | Channel 1 Low-side drive output, Ron = 1.5 Ω (typ) |
| 12 | GND (Note 1) | Ground | Ground connection |
| 13 | NAD | LV analog input/output | Node Addressing via external resistor (NAD selection) |
| 14 | CONF | LV analog input/output | Defines virtual node configuration position via external resistor |

NOTE: (LV = Low Voltage)

1. Pins 3 and 12 must be shorted externally.

Table 2. EXTERNAL COMPONENTS SPECIFICATION (See Figure 2)

| Component | Function | Value | Unit | Tolerance |
|--------------------|---|---|------|-------------|
| C _{VBB} | Decoupling capacitor on battery line, ceramic (X7R) | 100 | nF | 20% |
| C _{Bulk} | Bulk capacitor (energy storage) | Depends on minimum battery voltage profile requirements | | |
| R _{NAD} | Resistor for defining NAD of device | 475 (Note 2) | Ω | 1% (Note 5) |
| R _{CONF1} | Resistor for defining device's position in virtual node | 10.0 (Note 3) | kΩ | 1% (Note 5) |
| R _{CONF2} | Resistor for defining device's position in virtual node | 1.00 (Note 4) | kΩ | 1% (Note 5) |
| D1 – D2 | Power supply diode for relays and NCV7748 | e.g. MRA4003T3G | | |
| D _{ESD} | Optional LIN ESD protection diode | e.g. NUP1105LT1G or MMBZ27x | | |

2. Node Address = 0x60

3. Position of device in the virtual node = A'

4. Position of device in the virtual node = B

5. This tolerance is required for every value of used resistors on NAD and CONF pins selected according to Table 6 and Table 7.

The initial 1% tolerance of resistors must not get worse than 3% over the application life time.

NCV7748

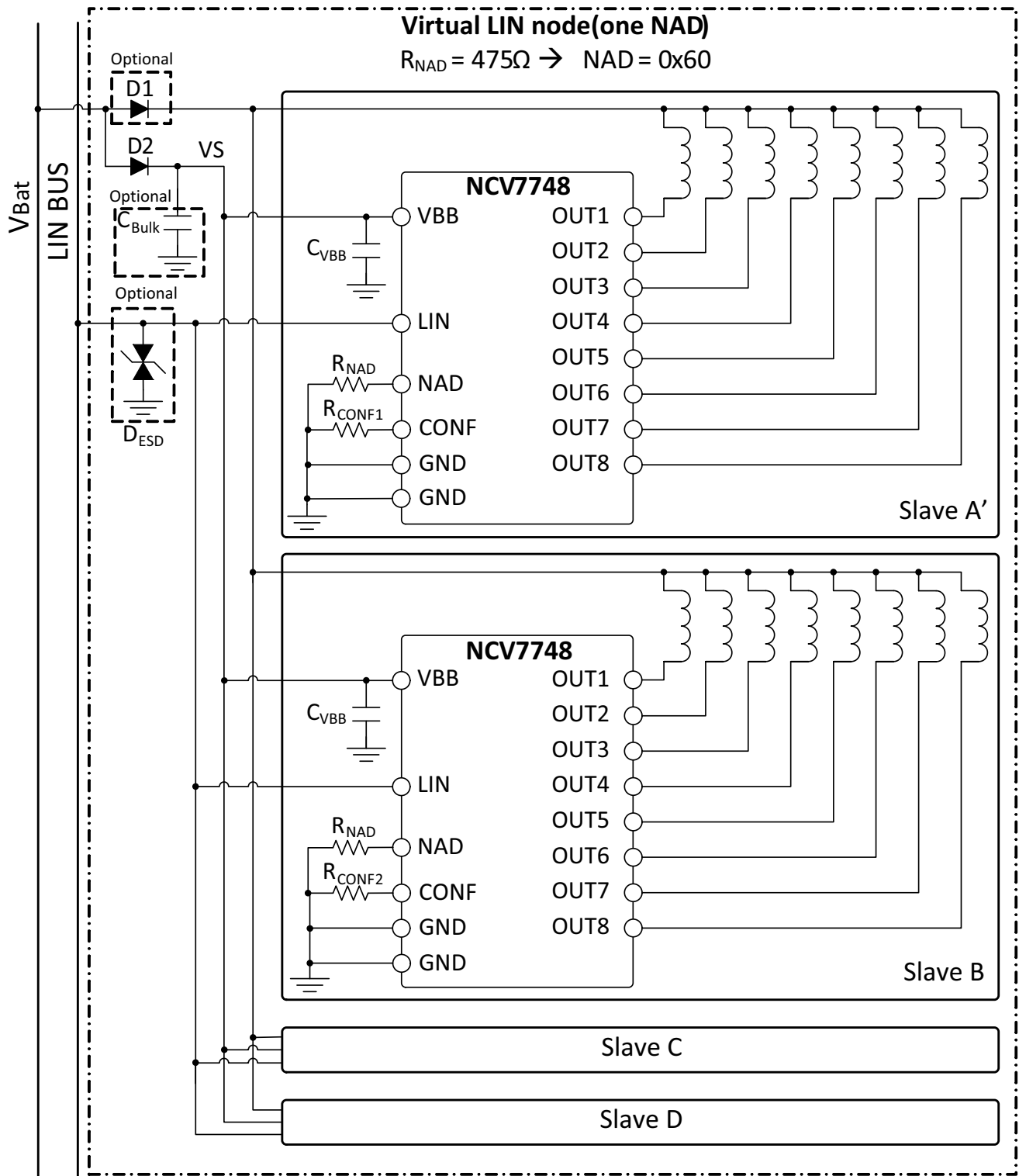

Figure 2. Application Diagram

Table 3. ABSOLUTE MAXIMUM RATINGS

| Symbol | Parameter | Min | Max | Unit |
|--|--|--|----------|------|
| Vmax_VBB | Power supply voltage | -0.3 | +40 | V |
| Vmax_LIN | DC voltage on LIN pin | -40 | +40 | V |
| Vmax_OUTx | OUT pins voltage range DC (voltage internally limited during flyback) | -0.3 | 38 | V |
| Vmax_OUTx_peak | OUT pins peak voltage range Internally limited. Applies to VBB range from 0 V to Vmax_VBB (powered and unpowered modes) | | 45 | V |
| I _{max_OUT4,8} | Maximum OUT4,8 pin current | -0.2 | 1.3 | A |
| I _{max_OUT1-3,5-7} | Maximum OUT1-3, 5-7 pin current | -0.2 | 1.2 | A |
| Clmp_sing Clmp_rep | Clamping energy Maximum (single pulse) OUT1-3, 5-7 (I _{OUT} = 300 mA, T _A = 150°C) OUT4,8 (I _{OUT} = 400 mA, T _A = 150°C) Repetitive (multiple) 2M pulses, VBB = 15 V, 63 Ω, 390 mH, T _A = 25°C | - | 40 65 | mJ |
| Vmax_CONF | CONF pin DC maximum voltage | -0.3 | 3.6 | V |
| Vmax_NAD | NAD pin DC maximum voltage | -0.3 | 3.6 | V |
| RSC_level | AEC Q100-012 Short Circuit Reliability Characterization | Grade A (minimum of 1 million of cycles) | | |
| ESD Human Body Model (100 pF, 1500 Ω) | All pins | -2 | +2 | kV |
| | Pin LIN to GND | -6 | +6 | |
| ESD following IEC 61000-4-2 (150 pF, 330 Ω) | Valid for pins VBB to GND and LIN to GND VBB pin with reverse-protection and filtering capacitor | -6 | +6 | kV |
| T _{j_mr} | Junction temperature | -40 | +150 | °C |
| T _{stg} | Storage Temperature Range | -55 | +150 | °C |
| MSL | Moisture Sensitivity Level (max. 260°C processing) | 3 | | |

Stresses exceeding those listed in the Maximum Ratings table may damage the device. If any of these limits are exceeded, device functionality should not be assumed, damage may occur and reliability may be affected.

Table 4. THERMAL CHARACTERISTICS

| Symbol | Parameter | Value | Unit |
|----------------------|---|-------|------|
| R _{th_ja_1} | Thermal Resistance, Junction-to-Ambient (1S0P) (Note 6) | 88 | °C/W |
| R _{th_jc_1} | Thermal Resistance, Junction-to-Case (1S0P) (Note 6) | 30 | |
| R _{tj_jl_1} | Thermal Resistance, Junction-to-Lead (1S0P) (Note 6) | 61 | |
| R _{th_ja_2} | Thermal Resistance, Junction-to-Ambient (2S2P) (Note 7) | 62 | °C/W |
| R _{th_jc_2} | Thermal Resistance, Junction-to-Case (2S2P) (Note 7) | 30 | |
| R _{th_jl_2} | Thermal Resistance, Junction-to-Lead (2S2P) (Note 7) | 52 | |

6. Based on JESD51-3, 1.2 mm thick FR4, 1S0P PCB with 2 oz. copper to 645 mm² spreader. Thermal Information is based on dissipating 125 mW on OUT1-3, 5-7 low-side drivers and 625 mW on OUT4 & 8 low-de drivers.

7. Based on JESD51-7, 1.2 mm thick FR4, 2S2P PCB with 2 oz. copper. Thermal Information is based on dissipating 125 mW on all eight output drivers.

NCV7748

Table 5. ELECTRICAL CHARACTERISTICS $6\text{ V} \leq V_{\text{BB}} \leq 18\text{ V}$, $-40^\circ\text{C} \leq T_j \leq 150^\circ\text{C}$; unless otherwise specified; $R_{\text{L(LIN-VBB)}} = 500\ \Omega$, unless otherwise specified. Typical values are given at $V(V_{\text{BB}}) = 12\text{ V}$ and $T_j = 25^\circ\text{C}$, unless otherwise specified.

| Symbol | Parameter | Conditions | Min | Typ | Max | Unit |
|--------|-----------|------------|-----|-----|-----|------|
|--------|-----------|------------|-----|-----|-----|------|

VBB SUPPLY

| | | | | | | |
|----------|---------------------------------|-------------------------|-----|---|-----|---|
| VBB | Supply Voltage | Functional (Note 8) | 4 | – | 38 | V |
| | | Parameter specification | 6 | – | 18 | |
| VBB_PORH | VBB POR threshold | VBB rising | 3.2 | – | 4 | V |
| VBB_PORL | VBB POR threshold | VBB falling | 3 | – | 3.7 | V |
| VBB_UV_H | UV–threshold voltage high level | VBB rising (Note 8) | 4 | – | 5 | V |
| VBB_UV_L | UV–threshold voltage low level | VBB falling (Note 8) | 3.8 | – | 4.7 | V |

8. Below 5 V on VBB in normal mode, the LIN bus will either stay recessive or comply with the voltage level specifications and transition time specifications as required by SAE J2602. It is ensured by the battery monitoring circuit (VBB_UV). Between VBB_UV and VBB_POR levels, OUTx pins status remains as commanded before undervoltage event. Above 18 V on VBB, LIN communication is operational (LIN pin toggling) but parameters are not guaranteed.

| | | | | | | |
|---------------|--|--|---|---|----|---------------|
| I_VBB_norm | VBB consumption in Normal mode | Normal mode, bus communication off, VLIN = VBB | – | – | 5 | mA |
| I_VBB_norm_c | VBB consumption in Normal mode, LIN active | Normal mode, bus communication on, VLIN = Low, No Load | – | – | 10 | mA |
| I_VBB_sleep | VBB consumption in Sleep mode | Sleep mode | – | – | 50 | μA |
| I_VBB_sleep_i | VBB consumption in Sleep mode | VBB = 12.8V; VLIN = VBB ; $T_j = 25^\circ\text{C}$ Guaranteed by design and prototype evaluations, not tested in production | – | – | 20 | μA |

OUT DRIVERS

| | | | | | | |
|--------------------|--|---|------|-----|-----|---------------|
| Ron_OUT1–3,5–7 | On–resistance to ground OUT1–3 and OUT5–7 | I(OUTx) = 90 mA | – | 1.5 | 3 | Ω |
| Ron_OUT4,8 | On–resistance to ground OUT4 and OUT8 | I(OUTx) = 340 mA | – | 0.8 | 1.6 | Ω |
| I_det_OUT4,8 | Overcurrent Detection Current OUT4 and OUT8 | OUTx = VBB | 0.75 | – | 1.3 | A |
| I_det_OUT1–3,5–7 | Overcurrent Detection Current OUT1–3, OUT5–7 | OUTx = VBB | 0.6 | – | 1.2 | A |
| Ileak_OUT1–8_r | Output leakage current in sleep mode (Note 9) | OUTx = VBB = 13.5 V, $T_j = 25^\circ\text{C}$ Guaranteed by design and prototype evaluations, not tested in production | – | – | 1 | μA |
| Ileak_OUT1–8 | Output leakage current in sleep mode (Note 9) | OUTx = VBB = 13.5 V | – | – | 5 | μA |
| Vclmp_OUT1–3,5–7 | Output clamp voltage | I(OUTx) = 90 mA | 38 | – | 45 | V |
| Vclmp_OUT4,8 | Output clamp voltage | I(OUTx) = 340 mA | 38 | – | 45 | V |
| V_diode_OUT1–3,5–7 | Output Body Diode Voltage | I(OUTx) = –90 mA | – | – | 1.1 | V |
| V_diode_OUT4,8 | Output Body Diode Voltage | I(OUTx) = –340 mA | – | – | 1.1 | V |
| V_th_open | Open Load Detection Threshold Voltage (OUT4, OUT8) | | 1 | – | 2.5 | V |
| I_th_open | Open Load Diagnostic Sink Current (OUT4, OUT8) | 1 V < OUTx < 13.5 V, Normal mode, drivers commanded OFF | 50 | 100 | 140 | μA |

9. In normal mode I_th_open load diagnostic current is flowing and does not allow a leakage current measurement.

MODE TRANSITIONS AND TIMEOUTS

| | | | | | | |
|-----------------|--|---|---|---|----|----|
| T_init | Sleep transition time after LIN wake–up detected (Duration of INIT mode) | See Figure 5 | – | – | 10 | ms |
| T_go_to_sleep | Time to go to sleep | No communication on LIN and/or undervoltage | 4 | – | 10 | s |
| T_go_to_sleep_i | Time to go to sleep after LIN frame received | 10.417 kbps or 19.2 kbps frame received | 4 | – | 5 | s |

NCV7748

Table 5. ELECTRICAL CHARACTERISTICS $6\text{ V} \leq V_{\text{BB}} \leq 18\text{ V}$, $-40^\circ\text{C} \leq T_{\text{J}} \leq 150^\circ\text{C}$; unless otherwise specified; $R_{\text{L(LIN-VBB)}} = 500\ \Omega$, unless otherwise specified. Typical values are given at $V(V_{\text{BB}}) = 12\text{ V}$ and $T_{\text{J}} = 25^\circ\text{C}$, unless otherwise specified.

| Symbol | Parameter | Conditions | Min | Typ | Max | Unit |
|--------|-----------|------------|-----|-----|-----|------|
|--------|-----------|------------|-----|-----|-----|------|

MODE TRANSITIONS AND TIMEOUTS

| | | | | | | |
|----------|---|---------------------|----|-----|-----|---------------|
| T_OC_del | Overcurrent Shut-Down Delay Time on OUTx pins | OUTx shorted to VBB | 3 | 15 | 50 | μs |
| T_OL_det | Open Load Detection Time OUT4, OUT8 | | 30 | 115 | 200 | μs |

THERMAL PROTECTION

| | | | | | | |
|------------------|--|--|-----|-----|-----|------------------|
| T_jsd | Global Thermal shut-down level | Guaranteed by design and prototype evaluations, not tested in production | 150 | 175 | 190 | $^\circ\text{C}$ |
| T_jsd_hys_global | Thermal shut-down hysteresis | Guaranteed by design and prototype evaluations, not tested in production | – | 20 | – | $^\circ\text{C}$ |
| T_jsd_OUT4,8 | Thermal shut-down level on OUT4 and OUT8 | Guaranteed by design and prototype evaluations, not tested in production | 150 | 175 | 190 | $^\circ\text{C}$ |
| T_jsd_hys_O4,8 | Thermal shut-down hysteresis | Guaranteed by design and prototype evaluations, not tested in production | – | 20 | – | $^\circ\text{C}$ |

LIN TRANSMITTER DC CHARACTERISTICS

| | | | | | | |
|----------------|----------------------------------|---|-----------------------|----|-----------------|------------|
| VLin_dom_LoSup | LIN dominant output voltage | Bus driven dominant; $V_{\text{BB}} = 7.3\text{ V}$ | – | – | 1.2 | V |
| VLin_dom_HiSup | LIN dominant output voltage | Bus driven dominant; $V_{\text{BB}} = 18\text{ V}$ | – | – | 2 | V |
| VLin_rec | LIN recessive output voltage | Bus left recessive; $I(\text{LIN}) = 0\text{ mA}$ | $V_{\text{BB}} - 1.5$ | – | V_{BB} | V |
| ILIN_lim | Short circuit current limitation | $V(\text{LIN}) = V_{\text{BB}} = 18\text{ V}$ | 40 | – | 200 | mA |
| Rslave_LIN | Internal pull-up resistance | Activated on prime LIN node only (See functional description) | 20 | 33 | 47 | k Ω |

LIN RECEIVER DC CHARACTERISTICS

| | | | | | | |
|------------------|--|---|------------------------------|-----|------------------------------|---------------|
| Vbus_dom_LIN | Bus voltage for dominant state | | – | – | $0.4 \times V_{\text{BB}}$ | V |
| Vbus_rec_LIN | Bus voltage for recessive state | | $0.6 \times V_{\text{BB}}$ | – | – | V |
| Vrec_dom_LIN | Receiver threshold | LIN bus recessive \rightarrow dominant | $0.4 \times V_{\text{BB}}$ | – | $0.5 \times V_{\text{BB}}$ | V |
| Vrec_rec_LIN | Receiver threshold | LIN bus dominant \rightarrow recessive | $0.5 \times V_{\text{BB}}$ | – | $0.6 \times V_{\text{BB}}$ | V |
| Vrec_cnt_LIN | Receiver center voltage | $(V_{\text{rec_dom_LIN}} + V_{\text{rec_rec_LIN}}) / 2$ | $0.475 \times V_{\text{BB}}$ | – | $0.525 \times V_{\text{BB}}$ | V |
| Vrec_hys_LIN | Receiver hysteresis | $(V_{\text{rec_rec_LIN}} - V_{\text{rec_dom_LIN}})$ | $0.05 \times V_{\text{BB}}$ | – | $0.175 \times V_{\text{BB}}$ | V |
| ILIN_off_dom | LIN output current, bus in dominant state | Normal mode, driver off; $V_{\text{BB}} = 12\text{ V}$; $V(\text{LIN}) = 0\text{ V}$ | –1 | – | – | mA |
| ILIN_off_dom_slp | LIN output current, bus in dominant state | Sleep mode, driver off; $V_{\text{BB}} = 12\text{ V}$; $V(\text{LIN}) = 0\text{ V}$ | –20 | –15 | –2 | μA |
| ILIN_off_rec | LIN output current, bus in recessive state | Driver off; $V_{\text{BB}} = 12\text{ V}$ | – | – | 2 | μA |
| ILIN_no_GND | Communication not affected | $V_{\text{BB}} = \text{GND} = 12\text{ V}$; $0 < V(\text{LIN}) < 18\text{ V}$ | –1 | – | 1 | mA |
| ILIN_no_VBB | LIN bus remains operational | $V_{\text{BB}} = \text{GND} = 0\text{ V}$; $0 < V(\text{LIN}) < 18\text{ V}$ | – | – | 5 | μA |

NCV7748

Table 5. ELECTRICAL CHARACTERISTICS $6\text{ V} \leq V_{\text{BB}} \leq 18\text{ V}$, $-40^\circ\text{C} \leq T_j \leq 150^\circ\text{C}$; unless otherwise specified; $R_{\text{L(LIN-VBB)}} = 500\ \Omega$, unless otherwise specified. Typical values are given at $V(V_{\text{BB}}) = 12\text{ V}$ and $T_j = 25^\circ\text{C}$, unless otherwise specified.

| Symbol | Parameter | Conditions | Min | Typ | Max | Unit |
|---|---|--|-------|-----|-------|---------------|
| LIN TRANSMITTER DYNAMIC CHARACTERISTICS (The following bus loads are considered: BL1 = 1 k Ω / 1 nF; BL2 = 660 Ω / 6.8 nF; BL3 = 500 Ω / 10 nF)(Resistor = Vbat to LIN, Capacitor = LIN to GND) | | | | | | |
| D1 | Duty Cycle 1 = $t_{\text{BUS_rec(min)}} / (2 \times \text{TBit})$ (see Figure 3) | $\text{TH}_{\text{Rec(max)}} = 0.744 \times V_{\text{BB}}$, $\text{TH}_{\text{Dom(max)}} = 0.581 \times V_{\text{BB}}$, Tbit = 50 μs , $V_{\text{BB}} = 7\text{ V to }18\text{ V}$, BL1, BL2, BL3 | 0.396 | | 0.5 | |
| D2 | Duty Cycle 2 = $t_{\text{BUS_rec(max)}} / (2 \times \text{TBit})$ (see Figure 3) | $\text{TH}_{\text{Rec(min)}} = 0.422 \times V_{\text{BB}}$, $\text{TH}_{\text{Dom(min)}} = 0.284 \times V_{\text{BB}}$, Tbit = 50 μs , $V_{\text{BB}} = 7.6\text{ V to }18\text{ V}$, BL1, BL2, BL3 | 0.5 | | 0.581 | |
| D3 | Duty Cycle 3 = $t_{\text{BUS_rec(min)}} / (2 \times \text{TBit})$ (see Figure 3) | $\text{TH}_{\text{Rec(max)}} = 0.788 \times V_{\text{BB}}$, $\text{TH}_{\text{Dom(max)}} = 0.616 \times V_{\text{BB}}$, Tbit = 96 μs , $V_{\text{BB}} = 7\text{ V to }18\text{ V}$ BL1, BL2, BL3 | 0.417 | | 0.5 | |
| D4 | Duty Cycle 4 = $t_{\text{BUS_rec(max)}} / (2 \times \text{TBit})$ (see Figure 3) | $\text{TH}_{\text{Rec(min)}} = 0.389 \times V_{\text{BB}}$, $\text{TH}_{\text{Dom(min)}} = 0.251 \times V_{\text{BB}}$, Tbit = 96 μs $V_{\text{BB}} = 7.6\text{ V to }18\text{ V}$, BL1, BL2, BL3 | 0.5 | | 0.59 | |
| T_fall_LIN | LIN falling edge (see Figure 4) BL1,BL2 | $V_{\text{BB}} = 12\text{ V}$; BL1, BL2 40% to 60% measurements extrapolated to 0% to 100% | | | 22.5 | μs |
| T_rise_LIN | LIN rising edge (see Figure 4) BL1,BL2 | $V_{\text{BB}} = 12\text{ V}$; BL1, BL2 40% to 60% measurements extrapolated to 0% to 100% | | | 22.5 | μs |
| T_sym_LIN | LIN slope symmetry BL1,BL2 | Normal mode $V_{\text{BB}} = 12\text{ V}$; BL1, BL2 | -6 | 0 | 6 | μs |
| T_fall_LIN_L3 | LIN falling edge (see Figure 4) BL3 | $V_{\text{BB}} = 12\text{ V}$; BL3 40% to 60% measurements extrapolated to 0% to 100% | | | 27 | μs |
| T_rise_LIN_L3 | LIN rising edge (see Figure 4) BL3 | $V_{\text{BB}} = 12\text{ V}$; BL3 40% to 60% measurements extrapolated to 0% to 100% | | | 27 | μs |
| T_sym_LIN_L3 | LIN slope symmetry BL3 | Normal mode; $V_{\text{BB}} = 12\text{ V}$; BL3 | -6 | 0 | 6 | μs |
| C_LIN | Capacitance of the LIN pin | Guaranteed by design; not tested in production | | 20 | 30 | pF |

LIN RECEIVER DYNAMIC CHARACTERISTICS

| | | | | | | |
|------------|------------------------------|--|----|----|-----|---------------|
| T_LIN_wake | Dominant duration for wakeup | | 30 | 90 | 150 | μs |
|------------|------------------------------|--|----|----|-----|---------------|

Product parametric performance is indicated in the Electrical Characteristics for the listed test conditions, unless otherwise noted. Product performance may not be indicated by the Electrical Characteristics if operated under different conditions.

NCV7748

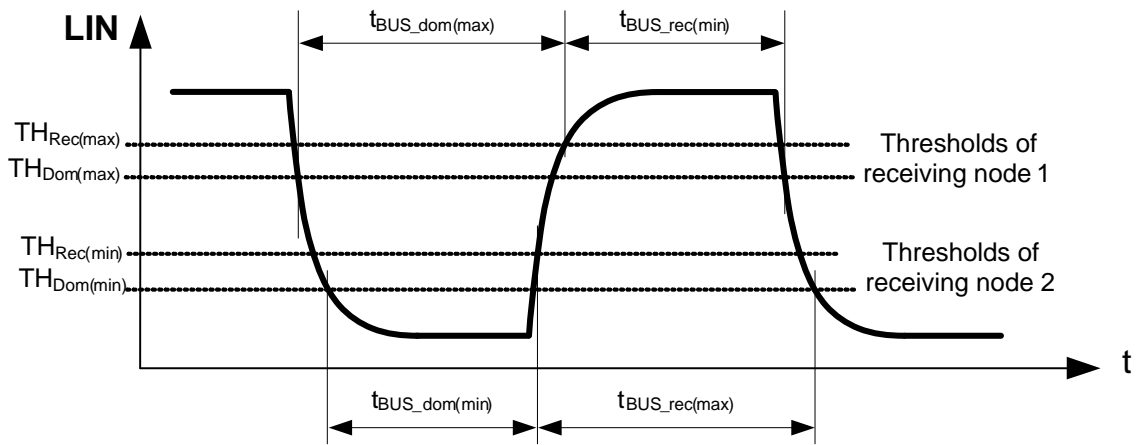

Figure 3. LIN Dynamic Characteristics – Duty Cycles

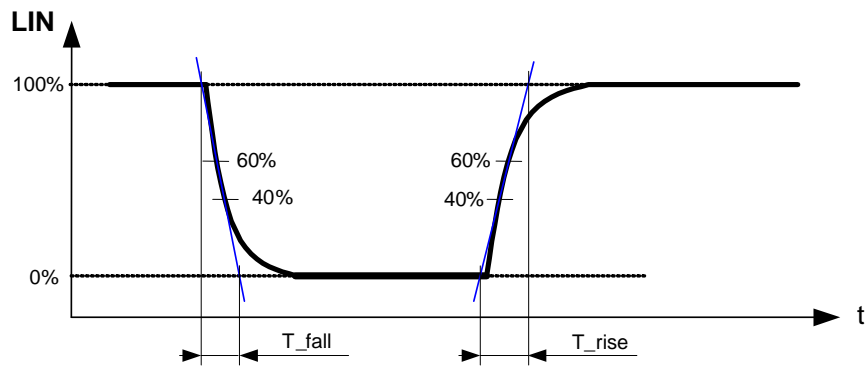

Figure 4. LIN Dynamic Characteristics – Transmitter Slope

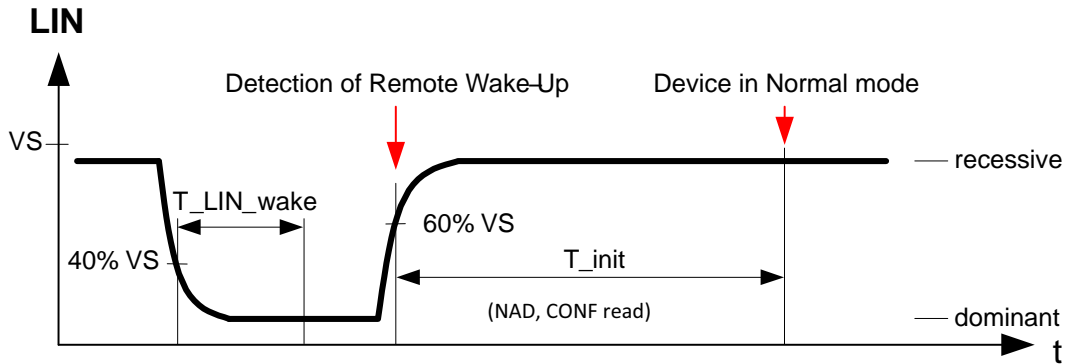

Figure 5. LIN Wake Up and Normal Mode Transition

Functional Description

The NCV7748 is an automotive eight channel low-side driver providing drive capability up to 0.75 A or 0.6 A per channel depending on channel selection. Output control is via a LIN bus with an optimized LIN command set allowing high flexibility while still maintaining compliance to the SAE J2602 LIN specification. Use of a virtual LIN node concept allows driving up to 32 channels with one LIN command.

Each output driver includes an output clamp for inductive loads.

All output drivers have overcurrent detection implemented. Select low side driver(s) offer additional fault reporting of open load (or short to ground) and local over temperature conditions which allows connection to a wiring harness outside of the module.

Operating Modes

The NCV7748 integrated circuit has **two BASIC modes** of operation:

1. **Normal mode** Fully functional.
2. **Sleep mode** Low quiescent current. Device is inactive waiting for LIN bus wake up.

The principal operating modes of the NCV7748 are shown in Figure 7.

There are also additional transition modes of operation: Un-powered, INIT, Reset and Undervoltage mode. Global thermal shutdown mode is shown in Figure 8. Within normal mode as shown in Figure 10, the device can transition into overcurrent mode (driver 1 to 3 and 5 to 7) or as shown in Figure 9 overcurrent/local thermal shutdown mode on drivers four and eight.

Un-Powered and INIT Mode

The device is held in power-on reset when VBB is below the *VBB_POR* level. All outputs are in HiZ state and LIN is disabled. Note: While LIN is disabled the weak pull up is activated (See *ILIN_off_dom_slp* parameter)

As soon as the VBB main supply exceeds the power-on reset level, the device enters the INIT Mode and begins an initialization sequence. ERR.0 bit is set high after the power-on reset. (See Table 15)

All the registers are set to their default values.

The device is reading the configuration resistors on the NAD and CONF pins. (Details of the device configuration based on NAD and CONF pins are in the Supported LIN commands chapter)

If the NAD and CONF pins are successfully read, the device enters normal mode. Otherwise (e.g. NAD, CONF pins shorted to ground, open or short between these pins) the device will enter Sleep mode. LIN is disabled during INIT mode and all OUTx outputs are in HiZ state.

The device stays in the INIT mode for a maximum time of *T_init*.

Sleep Mode

Sleep mode is entered from Normal mode or Undervoltage mode if there is no activity on the bus for longer time than limited by the *T_go_to_sleep* parameter. No activity is defined as no transition from recessive to dominant.

Another way to enter the Sleep mode from the Normal mode is successful reception of the Go to sleep command. (See Supported LIN commands chapter).

In Sleep Mode all outputs are off, the device is in Wake-up mode and there is no change in the state of the ERR bits.

If a valid LIN wake-up (See *T_LIN_wake*) is detected, the Sleep mode transitions to INIT mode.

Internal LIN Transceiver Modes

Within the NCV7748, the LIN transceiver has three internal modes of operation, normal active mode (On), Disabled mode (OFF), and within the NCV7748 sleep mode the LIN transceiver is powered down waiting to be woken up and is said to be in Wake-Up Mode.

LIN is active (On) during Normal Mode.

LIN is disabled (Off) during Un-Powered mode, Reset, and INIT mode.

In Sleep Mode, the internal LIN transceiver is in Wake-Up Mode waiting for a dominant signal (low) with a minimum continuous duration of *T_LIN_wake*. A remote wake-up occurs after *T_LIN_wake* and the return of LIN to a high (60% VS) (Figure 5).

When a LIN Wake-Up occurs, the device enters the INIT mode.

Reset Mode

After a successful reception of a broadcast or targeted reset frame, the device enters Reset mode.

All registers are set to their default values and ERR.0 bit is set to high.

Normal Mode

Normal mode is entered after a successful transition through the INIT mode.

The internal LIN transceiver is active and drivers are set as defined by LIN commands. (Details are in Supported LIN commands chapter.)

Open Load Detection

Open Load Detection is achieved for drivers OUT4 and OUT8 with the Open Load Detection Threshold Voltage reference voltage (*V_th_open*) and its corresponding Open Load Diagnostic Sink Current (*I_th_open*) (when the output driver [OUT4 or OUT8] is off) in both normal mode and after power up. The output driver maintains its functionality with and without the output status bit set (i.e. it can turn on and off).

NCV7748

During normal operation, the open circuit impedance (R_{oc}) is zero ohms (Figure 6). This sets the voltage on OUT4 or OUT8 to VS volts. As long as VS is above V_{th_open} no open circuit fault will be recognized. The voltage appearing on OUT4 or OUT8 is a result of VS and the voltage drop across R_{oc} realized by the current flow created by I_{th_open} .

The NCV7748 voltage level trip points are referenced to ground. The threshold range is between 1.0 V and 2.5 V.

With a nominal battery voltage (VS) of 14 V, the resultant worst case thresholds of detection are as follows.

$$\frac{(VS - \text{OpenLoadDetectionThresholdVoltage})}{\text{OpenLoadDiagnosticSinkCurrent}} = \text{OpenLoad Impedance}$$

$$\frac{(14 \text{ V} - 2.5 \text{ V})}{140 \mu\text{A}} = 82.1 \text{ K}\Omega$$

$$\frac{(14 \text{ V} - 1.0 \text{ V})}{50 \mu\text{A}} = 260 \text{ K}\Omega$$

The maximum impedance detection threshold is 260 K Ω , but may not be detected until the minimum impedance of 82.1 K Ω .

Note – Electrical parameter magnitudes in the Open Load Detection diagram are shown as typical values.

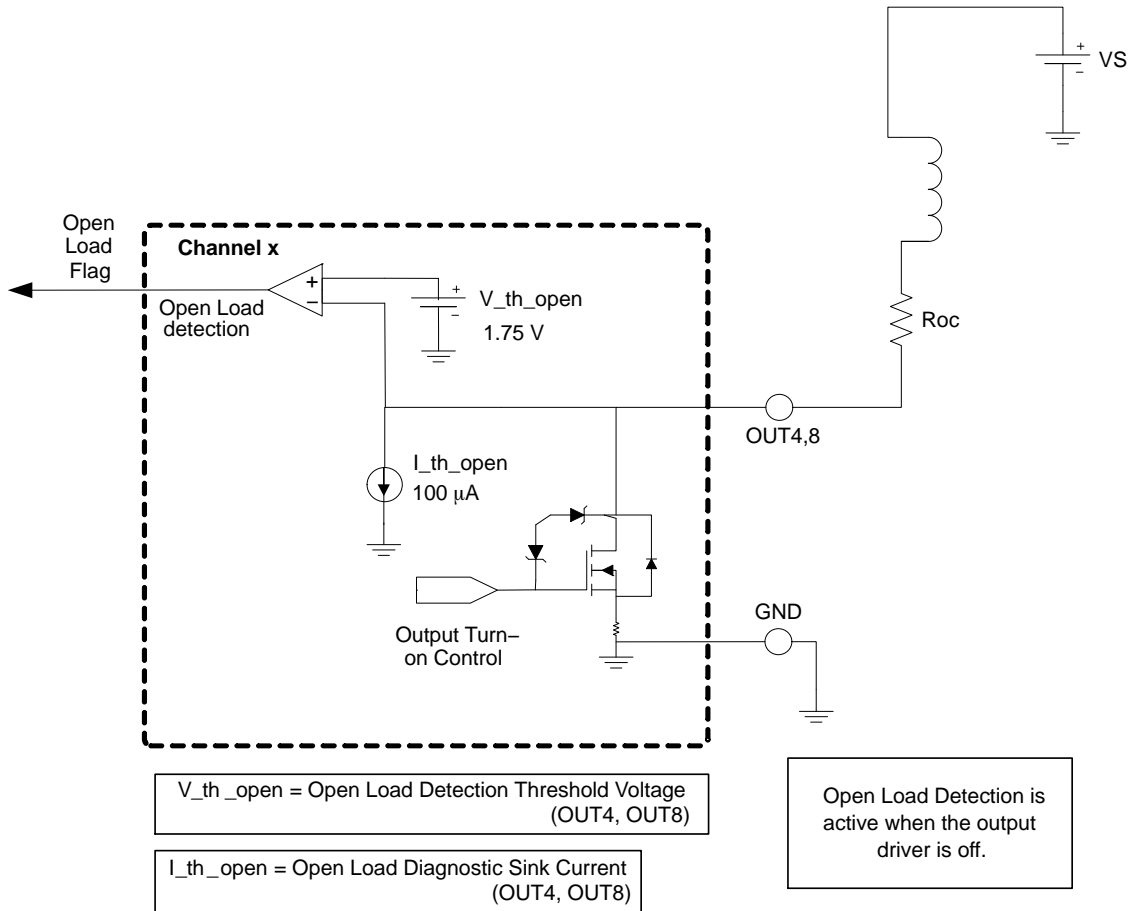

Figure 6. Open Load Detection

Dual Reporting APPINFO 01000b

Both **Local Thermal Shutdown** and **Overcurrent Detection** are reported in the APPINFO register (01000b) as an OR'd bit. Either or both of these conditions will be reported as a "1". (See Table 17)

Local Thermal Shutdown

Output 4 and 8 have local thermal shutdown sensors protecting the drivers. If OUT4/8 thermal shutdown threshold ($T_{jsd_OUT4,8}$) is reached, the corresponding driver is latched off and fault flags are set. The local thermal shutdown on OUT4 and OUT8 is latched in the OUT Status readout register (See Table 16) as well as in the APPINFO register. (See Table 17, APPINFO.3 bit).

The only way to leave the overcurrent / local thermal shutdown state and at the same time clear out the output status and APPINFO register is to command OFF the affected driver.

The overcurrent /local thermal shutdown info in the APPINFO register is only kept high if Global thermal shutdown is not activated. Global thermal shutdown has higher priority and masks APPINFO.3 to low as long as Global thermal shutdown is active. This is to avoid having both APPINFO.2 and APPINFO.3 bits high at the same time as this combination is reserved in some systems for ECU fault diagnostics.

Overcurrent Detection

All eight drivers have overcurrent detection implemented. Drivers are latched off if the load current exceeds I_{det_OUTx} level for the time longer than T_{OC_del} (see Figures 9 and 10).

The overcurrent status on OUT4 and OUT8 is latched in the OUT Status readout register (See Table 16) as well as in the APPINFO register. (See Table 17, APPINFO.3 bit). On OUT1–3 and OUT5–7 the overcurrent status is latched in the OUT status register but not in the APPINFO register.

The only way to leave the overcurrent / local thermal shutdown state and at the same time clear out the output status and APPINFO register is to command OFF the affected driver.

The overcurrent / local thermal shutdown info in the APPINFO register is only kept high if Global thermal shutdown is not activated. Global thermal shutdown has higher priority and masks APPINFO.3 to low as long as Global thermal shutdown is active. This is to avoid having both APPINFO.2 and APPINFO.3 bits high at the same time as this combination is reserved in some systems for ECU fault diagnostics.

Global Thermal Shutdown Mode

The device junction temperature is monitored in order to avoid permanent degradation or damage of the chip. Junction temperature exceeding the Shutdown level T_{J_SD} puts the chip into Thermal Shutdown mode. (See Figure 8)

In Global thermal Shutdown mode, all OUTx drivers are deactivated, LIN transceiver remains active. APPINFO.2 bit is set high and APPINFO.3 as mentioned above is

masked to low (00100b). The mode is automatically exited if the junction cools down below the T_{J_SD} minus hysteresis $T_{jsd_hys_global}$ threshold. APPINFO.2 is not latched and is cleared when mode is exited.

Undervoltage Mode

If the voltage on the battery pin VBB goes below VBB_UV_L , the device enters Undervoltage mode. LIN is disabled (both transmitter and receiver) but drivers' status remains unchanged.

The device returns to Normal mode if the battery voltage goes above VBB_UV_H level. Un-powered mode is entered if VBB voltage drops below VBB_POR_L level.

As LIN timeout counter is running during the Undervoltage mode as well, the device is suspended to the Sleep mode when the timeout of $T_{go_to_sleep}$ elapses.

Error Field (ERR [2:0]) & APPINFO (J2602 STATUS BYTE)

The NCV7748 uses a 3 bit error field (ERR[2:0]) as specified in SAE J2602 for LIN Protocol Error reporting and is reported in response to the GET STATUS COMMAND and the GET NODE ID COMMAND. Errors are reported and cleared in response to these commands in a serial prioritized sequence. The 8 Error states are reported from highest priority (7) to lowest priority (0) which is No Error. Each command clears just one error as they are reported until all errors are clear.

Error State Definitions

(See Table 15)

No Error – No detected fault.

Reset – VBB POR, Targeted reset (from normal mode), Broadcast reset (from normal mode)

Data Error – A TxD Bit Error shall be detected when the bit or byte value that is received is different from the bit or byte value that is transmitted.

Data Checksum – A Checksum Error shall be detected if the sum of all values and subtract 255 every time the sum is greater or equal to 256 over all received data bytes and the protected identifier (when using enhanced checksum) and the received checksum byte field does not result in \$FF.

Byte Field Framing Error – The receiver shall detect a Byte Field Framing Error if the ninth bit after a valid start bit is dominant (low).

ID Parity Error – The receiver shall detect an ID Parity Error if the received ID parity (bits 6 & 7) does not match the ID parity calculated from $P0 = ID0 \oplus ID1 \oplus ID2 \oplus ID4$ (1), $P1 = \neg (ID1 \oplus ID3 \oplus ID4 \oplus ID5)$.

APPINFO [4:0]

The NCV7748 uses a 5 bit application specific field as specified in SAE J2602 for reporting the APPINFO register (reference Table 17) and is reported in response to the GET STATUS COMMAND and the GET NODE ID COMMAND. Global Thermal Shutdown is prioritized to report ahead of OUT4, OUT8 Thermal Shutdown or OUT4, OUT8 Overcurrent. All thermal shutdown and overcurrent faults must be cleared by commanding off the affected driver before they can be turned back on. Commanding off the affected driver will also clear APPINFO.

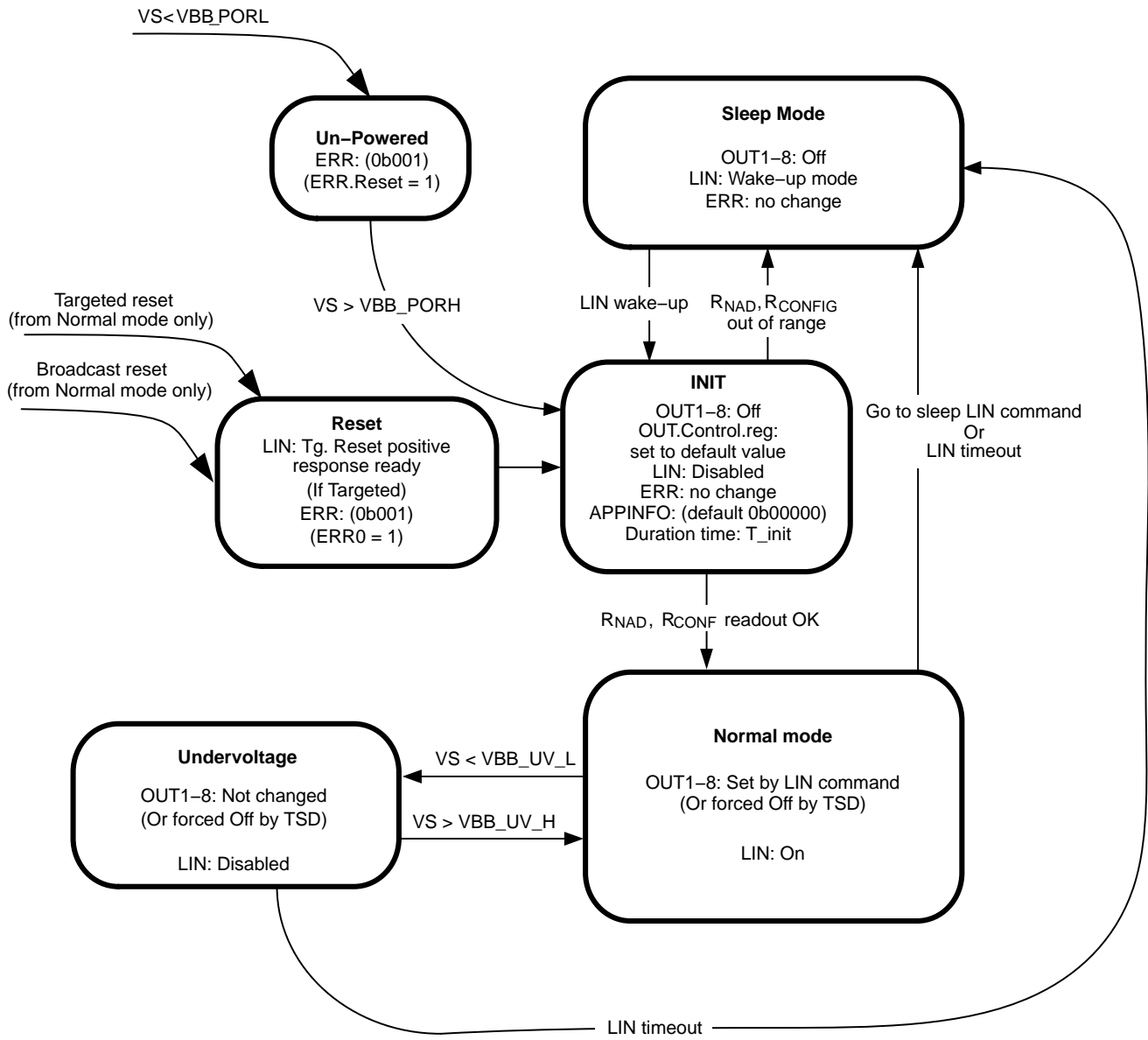

Figure 7. Basic State Diagram

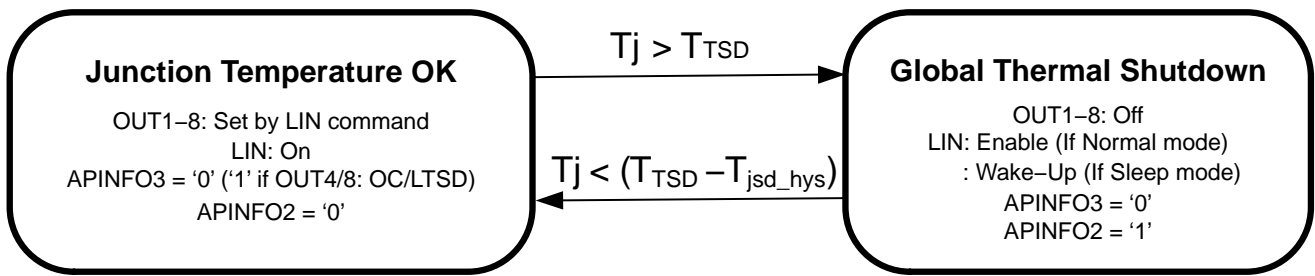

Figure 8. Global Thermal Shutdown State Diagram

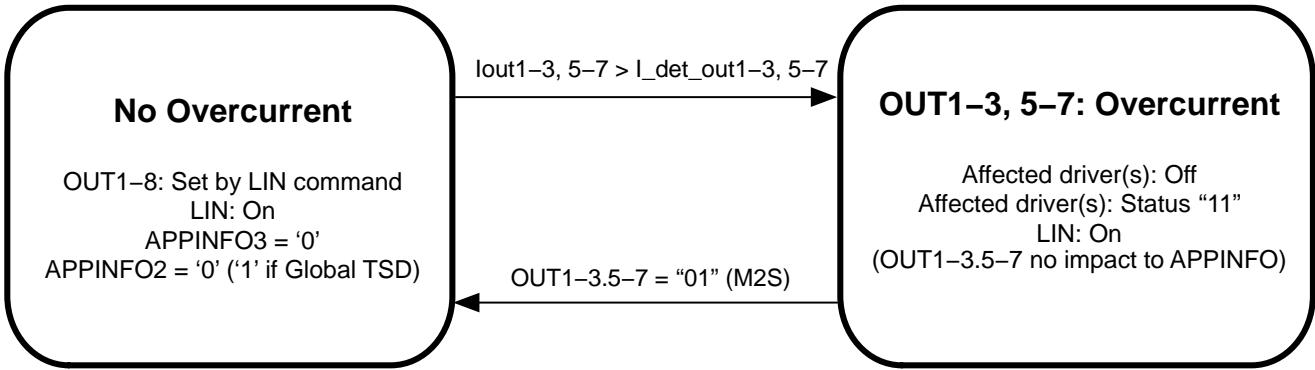

Figure 9. OUT1–3 and OUT5–7 Overcurrent Protection

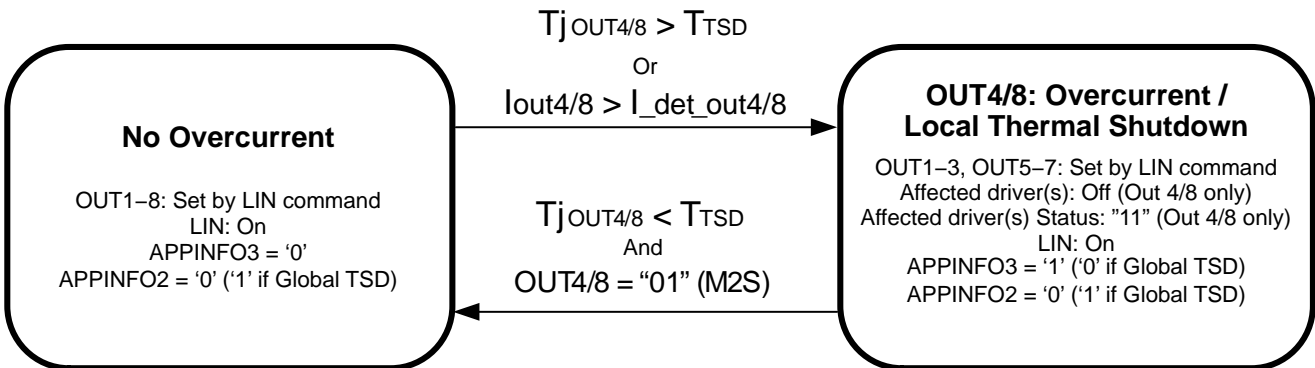

Figure 10. OUT4/8 Overcurrent/local Thermal Shutdown State Diagram

M2S = Master to Slave Output Turn-Off Command

LIN Physical Layer

NCV7748 integrates an on-chip LIN transceiver interface between the physical LIN bus and the integrated LIN protocol controller. (See Supported LIN Commands)

This LIN physical layer is compatible to LIN2.x and J2602 specifications.

The NCV7748 LIN2.2 compliant physical layer can be combined on the network with all the previous LIN physical layers.

The NCV7748 LIN transceiver consists of a transmitter, receiver and wakeup detector.

Automatic Bit Rate Detection

Automatic bit rate synchronization to any LIN master bit rate between 1 kbps and 20 kbps. Note: the parameter *T_{go_to_sleep_i}* in the MODE TRANSITIONS AND TIMEOUTS table is the only effected parameter for the two mentioned communication speeds.

Supported LIN Commands

A virtual LIN node concept was used to address the NCV7748. (See Figure 11). It allows

- Flexibility to drive up to 32 relays on one node via a LIN bus
- Compliance to SAE J2602 specification
- Provide enough free NAD addresses to other nodes on the LIN bus.

Virtual Slave Node Address

Virtual node means that up to four LIN relay driver chips will share the same NAD. That means up to four devices can be externally addressable as one LIN node.

The NAD of the virtual node is defined by the value of a resistor on the pin NAD according to the Table 6.

The external resistor value is compared to internal references and decoded during the INIT mode.

Table 6. VIRTUAL SLAVE NODE ADDRESS

| | | | | | | | |
|------------------|------|--------|--------|--------|--------|--------|--------|
| NAD | 0x60 | 0x62 | 0x64 | 0x66 | 0x68 | 0x6A | 0x6C |
| R _{NAD} | 475Ω | 1.00kΩ | 2.21kΩ | 4.75kΩ | 10.0kΩ | 22.1kΩ | 47.5kΩ |

Virtual Slave Node Configuration

The position of the particular device within the virtual node is defined by the value of a resistor on the CONF pin (see Table 7) decoded during the INIT mode.

Table 7. DEVICE IDENTIFICATION WITHIN THE VIRTUAL LIN NODE

| Slave | A | B | C | D | A' | B' | C' | D' |
|-------------------|------|--------|--------|--------|--------|--------|--------|---------|
| R _{CONF} | 475Ω | 1.00kΩ | 2.21kΩ | 4.75kΩ | 10.0kΩ | 22.1kΩ | 47.5kΩ | 100.0kΩ |

Every virtual node must have exactly one prime node (marked with A', B', C' or D'). The prime node will respond to the Targeted Reset and Get Node ID (of the virtual node). Non-prime nodes will not respond to these commands.

Only the prime node has an internal LIN pull-up resistor activated (see *R_{slave_LIN}* parameter in electrical characteristics section).

Table 9 shows an overview of all the supported LIN commands.

ID to PID Mapping

The relationship between protected identifier (PID) and message ID is explained in Table 8. The PID field consists of two sub-fields; the frame identifier and the parity. Bits 0 to 5 are the frame identifier and bits 6 and 7 (P0, P1) are the parity.

Table 8. ID TO PID MAPPING

| PID | | | | | | | |
|--------|----|----|---|---|---|---|---|
| Parity | | ID | | | | | |
| P1 | P0 | 5 | 4 | 3 | 2 | 1 | 0 |
| 1 | 0 | 0 | 0 | 0 | 0 | 0 | 0 |

P0 and P1 are used for parity check over <ID0> to <ID5>, (compliant to LIN2.x specification)

P0 = <ID0> ⊕ <ID1> ⊕ <ID2> ⊕ <ID4> (even parity) and P1 = NOT(<ID1> ⊕ <ID3> ⊕ <ID4> ⊕ <ID5>) (odd parity)

NCV7748

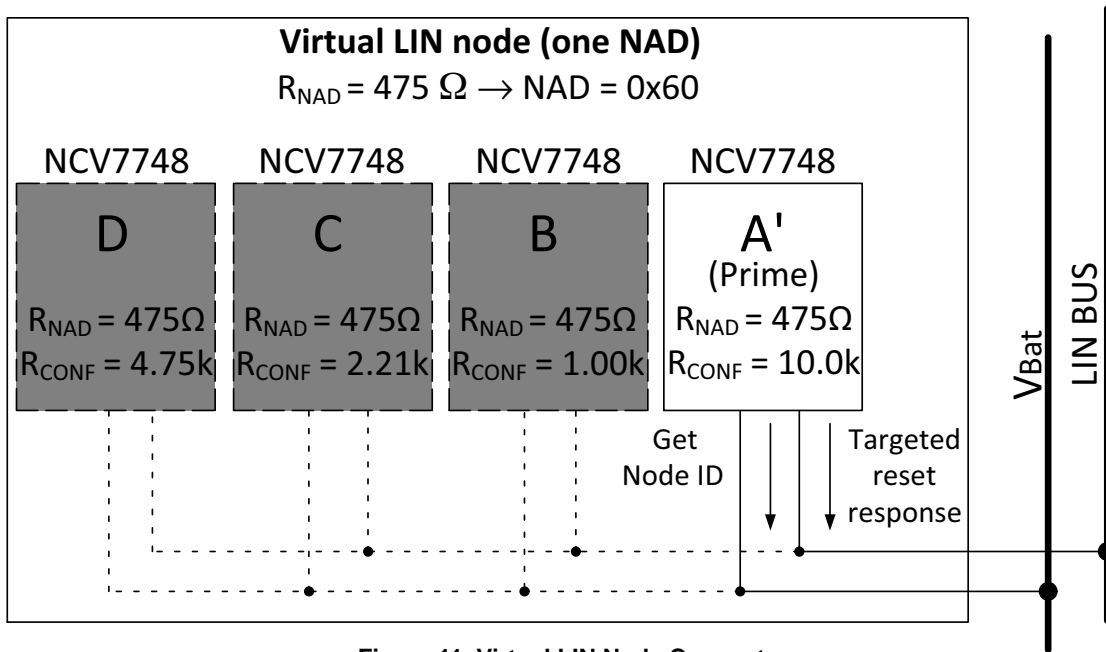

Figure 11. Virtual LIN Node Concept

Table 9. SUMMARY OF SUPPORTED LIN COMMANDS

| Frame Type | Description | Data Length | PID[7:0] | Spec |
|-----------------------------------|---|-------------|--|---------|
| Output Control | Sets all outputs in one virtual node | 8 | Depends on NAD (See Table 12) | N/A |
| Get Node ID | Reads identity of prime device in virtual node. (In frame slave Response) | 8 | Depends on NAD (See Table 23) | N/A |
| Get Status | Reads diagnostics of one device (LS driver). (In frame slave Response) | 8 | Depends on CONF (See Table 7) and NAD (See Table 18) | N/A |
| Targeted Reset master Request | Re-initialization of one virtual node. This includes all devices on the virtual node. | 8 | 0x3C | J2602-1 |
| Targeted Reset slave response | Positive response by prime device | 8 | 0x7D | |
| Read by identifier master request | Reads identity of device supplier | 8 | 0x3C | LIN2.2 |
| Read by Identifier slave Response | Successfully processed request (Positive Response by prime) | 8 | 0x7D | |
| | Slave could not process the request (Negative Response by prime) | 8 | | |
| Broadcast Reset | Re-initialization of all nodes | 8 | 0x3C | J2602-1 |
| Goto Sleep | All devices enter Sleep Mode | 8 | 0x3C | LIN2.2 |

OUTPUT CONTROL FRAME

Table 10. OUTPUT CONTROL COMMAND

| | Byte | Content | Structure | | | | | | | |
|--------|----------|-------------------|-----------|-------|-----------|-------|-----------|-------|-----------|-------|
| | | | Bit 7 | Bit 6 | Bit 5 | Bit 4 | Bit 3 | Bit 2 | Bit 1 | Bit 0 |
| Master | 0 | Identifier | PID | | | | | | | |
| | 1 | Data 1 | OUT4_A/A' | | OUT3_A/A' | | OUT2_A/A' | | OUT1_A/A' | |
| | 2 | Data 2 | OUT8_A/A' | | OUT7_A/A' | | OUT6_A/A' | | OUT5_A/A' | |
| | 3 | Data 3 | OUT4_B/B' | | OUT3_B/B' | | OUT2_B/B' | | OUT1_B/B' | |
| | 4 | Data 4 | OUT8_B/B' | | OUT7_B/B' | | OUT6_B/B' | | OUT5_B/B' | |
| | 5 | Data 5 | OUT4_C/C' | | OUT3_C/C' | | OUT2_C/C' | | OUT1_C/C' | |
| | 6 | Data 6 | OUT8_C/C' | | OUT7_C/C' | | OUT6_C/C' | | OUT5_C/C' | |
| | 7 | Data 7 | OUT4_D/D' | | OUT3_D/D' | | OUT2_D/D' | | OUT1_D/D' | |
| | 8 | Data 8 | OUT8_D/D' | | OUT7_D/D' | | OUT6_D/D' | | OUT5_D/D' | |
| 9 | Checksum | Enhanced Checksum | | | | | | | | |

The output Control command is used to control all the connected drivers in the virtual node. Each data byte controls up to four channels where each two bits are assigned to one output channel. (See Table 10) The decoding of the 2-bit output control is shown in the Table 11.

Table 11. OUTPUT ENCODING

| OUTx_A[1] | OUTx_A[0] | Output |
|-----------|-----------|-----------|
| 0 | 0 | No change |
| 0 | 1 | OUTx Off* |
| 1 | 0 | OUTx On |
| 1 | 1 | No change |

*Outputs OUT4 and OUT8 have open load diagnostics, which are enabled when the output is off.

The ID of the control frame depends on the chosen NAD of the virtual LIN node. The mapping of the ID to be used based on NAD is shown in Table 12.

Table 12. NAD TO OUTPUT CONTROL COMMAND ID/PID MAPPING

| R _{NAD} | NAD | ID | PID |
|------------------|------|------|------|
| 475 Ω | 0x60 | 0x01 | 0xC1 |
| 1.00 kΩ | 0x62 | 0x09 | 0x49 |
| 2.21 kΩ | 0x64 | 0x11 | 0x11 |
| 4.75 kΩ | 0x66 | 0x19 | 0x99 |
| 10.0 kΩ | 0x68 | 0x21 | 0x61 |
| 22.1 kΩ | 0x6A | 0x29 | 0xE9 |
| 47.5 kΩ | 0x6C | 0x31 | 0xB1 |

Table 13 shows NAD to ID mapping in the context of SAEJ2602 spec.

Table 13. OUTPUT CONTROL COMMAND NAD TO ID MAPPING LINKED TO SAEJ2602 SPEC

| NAD | Message ID | PID | NAD | Message ID | PID | NAD | Message ID | PID | NAD | Message ID | PID | |
|------|------------|------|------|------------|------|------|------------|------|------|------------------------|------------------------|--|
| \$60 | \$0 | | \$64 | \$10 | | \$68 | \$20 | | \$6C | \$30 | | |
| | \$1 | 0xC1 | | \$11 | 0x11 | | \$21 | 0x61 | | \$31 | 0xB1 | |
| | \$2 | | | \$12 | | | \$22 | | | \$32 | | |
| | \$3 | | | \$13 | | | \$23 | | | \$33 | | |
| | \$4 | | | \$14 | | | \$24 | | | \$34 | | |
| | \$5 | | | \$15 | | | \$25 | | | \$35 | | |
| | \$6 | | | \$16 | | | \$26 | | | \$36 | | |
| | \$7 | | | \$17 | | | \$27 | | | \$37 | | |
| \$62 | \$8 | | \$66 | \$18 | | \$6A | \$28 | | \$6E | No Message IDs defined | | |
| | \$9 | 0x49 | | \$19 | 0x99 | | \$29 | 0xE9 | | \$6F | No Message IDs defined | |
| | \$0A | | | \$1A | | | \$2A | | | | | |
| | \$0B | | | \$1B | | | \$2B | | | | | |
| | \$0C | | | \$1C | | | \$2C | | | | | |
| | \$0D | | | \$1D | | | \$2D | | | | | |
| | \$0E | | | \$1E | | | \$2E | | | | | |
| | \$0F | | | \$1F | | | \$2F | | | | | |

GET STATUS AND DIAGNOSTIC

Table 14. GET STATUS REQUEST

| | Byte | Content | Structure | | | | | | | |
|--------|------|------------|-------------------|-------|-------------|---------|-------------|-------|-------------|-------|
| | | | Bit 7 | Bit 6 | Bit 5 | Bit 4 | Bit 3 | Bit 2 | Bit 1 | Bit 0 |
| Master | 0 | Identifier | PID | | | | | | | |
| Slave | 1 | Data 1 | ERR2 | ERR1 | ERR0 | APPINFO | | | | |
| | 2 | Data 2 | OUT4 STATUS | | OUT3 STATUS | | OUT2 STATUS | | OUT1 STATUS | |
| | 3 | Data 3 | OUT8 STATUS | | OUT7 STATUS | | OUT6 STATUS | | OUT5 STATUS | |
| | 4 | Data 4 | 0x00 (NULL) | | | | | | | |
| | 5 | Data 5 | 0x00 (NULL) | | | | | | | |
| | 6 | Data 6 | 0x00 (NULL) | | | | | | | |
| | 7 | Data 7 | 0x00 (NULL) | | | | | | | |
| | 8 | Data 8 | 0x00 (NULL) | | | | | | | |
| | 9 | Checksum | Enhanced Checksum | | | | | | | |

GET STATUS COMMAND

The Get Status Request frame (see Table 14) is issued by the master to receive application specific diagnostics.

The error bits decrypted from Data1 of this command are as per SAEJ2602 in Table 15.

The ERR.[2:0] bits are cleared by readout. That means every command response containing ERR.[2:0] clears the error register.

Every driver status (Data 2 and 3) is stored in two bits of information. Only drivers OUT4 and OUT8 allow readout of open load fault (OL) and local TSD. All drivers flag overcurrent info. (See Table 16)

Table 17 describes APPINFO register content.

Table 15. J2602-1 ERROR FIELD

| ERR2 | ERR1 | ERR0 | Error States | Priority |
|------|------|------|--------------------------|-------------|
| 0 | 0 | 0 | No Error | 0 (lowest) |
| 0 | 0 | 1 | Reset | 1 |
| 0 | 1 | 0 | Reserved | 2 |
| 0 | 1 | 1 | Reserved | 3 |
| 1 | 0 | 0 | Data Error | 4 |
| 1 | 0 | 1 | Data Checksum | 5 |
| 1 | 1 | 0 | Byte Field Framing Error | 6 |
| 1 | 1 | 1 | ID Parity Error | 7 (highest) |

Table 16. OUT STATUS READOUT

| STATUS | Output Command | Description | Note |
|--------|----------------|---|-------------------------------|
| 00b | OFF | Open Load Fault (non-latching) | Only OUT4/8 |
| 01b | OFF | Per setting or active Global TSD | All OUTx, Default after reset |
| 10b | ON | Per setting | All OUTx |
| 11b | ON | Latched OFF from ON state due to TSD/OC | TSD / OUT4/8; OC on all OUTx |

Table 17. APPINFO REGISTER

| APPINFO | Error States |
|------------------------|--|
| 00000b | Default – No Failure to Report |
| 00100b | Global Thermal Shutdown |
| 01000b | OUT4 & OUT8 Thermal Shutdown or Overcurrent |
| 1XXXXb | Not Supported (Slave is not requiring configuration / calibration) |
| X11XXb | Not Supported (No ECU fault reporting) |
| XXX1Xb | Not Supported (No input fault reporting) |
| XXXX1b | Not Supported |
| NOTE: "X" = don't care | |

NCV7748

Table 18 defines the PID depending on NAD and CONF.

Table 18. GET STATUS ID MAPPING

| | | ID | PID | ID | PID | ID | PID | ID | PID |
|------------------|-------|------|------|------|------|------|------|------|------|
| | Slave | A | | B | | C | | D | |
| | | A' | | B' | | C' | | D' | |
| R _{NAD} | NAD | | | | | | | | |
| 475 Ω | 0x60 | 0x02 | 0x42 | 0x03 | 0x03 | 0x04 | 0xC4 | 0x05 | 0x85 |
| 1.00 kΩ | 0x62 | 0x0A | 0xCA | 0x0B | 0x8B | 0x0C | 0x4C | 0x0D | 0x0D |
| 2.21 kΩ | 0x64 | 0x12 | 0x92 | 0x13 | 0xD3 | 0x14 | 0x14 | 0x15 | 0x55 |
| 4.75 kΩ | 0x66 | 0x1A | 0x1A | 0x1B | 0x5B | 0x1C | 0x9C | 0x1D | 0xDD |
| 10.0 kΩ | 0x68 | 0x22 | 0xE2 | 0x23 | 0xA3 | 0x24 | 0x64 | 0x25 | 0x25 |
| 22.1 kΩ | 0x6A | 0x2A | 0x6A | 0x2B | 0x2B | 0x2C | 0xEC | 0x2D | 0xAD |
| 47.5 kΩ | 0x6C | 0x32 | 0x32 | 0x33 | 0x73 | 0x34 | 0xB4 | 0x35 | 0xF5 |

Table 19 shows get status ID to NAD and node position within a virtual node in context of SAEJ2602 spec.

Table 19. GET STATUS ID MAPPING LINKED TO SAEJ2602 SPEC

| NAD | Message ID | PID | NAD | Message ID | PID | NAD | Message ID | PID | NAD | Message ID | PID |
|------|------------|------|------|------------|------|------|------------|------|------|------------------------|------|
| \$60 | \$0 | | \$64 | \$10 | | \$68 | \$20 | | \$6C | \$30 | |
| | \$1 | | | \$11 | | | \$21 | | | \$31 | |
| | \$2 | 0x42 | | \$12 | 0x92 | | \$22 | 0xE2 | | \$32 | 0x32 |
| | \$3 | 0x03 | | \$13 | 0xD3 | | \$23 | 0xA3 | | \$33 | 0x73 |
| | \$4 | 0xC4 | | \$14 | 0x14 | | \$24 | 0x64 | | \$34 | 0xB4 |
| | \$5 | 0x85 | | \$15 | 0x55 | | \$25 | 0x25 | | \$35 | 0xF5 |
| | \$6 | | | \$16 | | | \$26 | | | \$36 | |
| | \$7 | | | \$17 | | | \$27 | | | \$37 | |
| \$62 | \$8 | | \$66 | \$18 | | \$6A | \$28 | | \$6E | No Message IDs defined | |
| | \$9 | 0xCA | | \$19 | | | \$29 | | | | |
| | \$0A | 0x8B | | \$1A | 0x1A | | \$2A | 0x6A | | | |
| | \$0B | 0x4C | | \$1B | 0x5B | | \$2B | 0x2B | | | |
| | \$0C | 0x0D | | \$1C | 0x9C | | \$2C | 0xEC | \$6F | No Message IDs defined | |
| | \$0D | | | \$1D | 0xDD | | \$2D | 0xAD | | | |
| | \$0E | | | \$1E | | | \$2E | | | | |
| | \$0F | | | \$1F | | | \$2F | | | | |

Example of the Get Status command

Reference Figure 12 for bit sequencing.

ID = 0x02 [Table ID] => PID = 0x42 [LIN2.2]
 (Reference Table 19)

Data1 = 0x08 => OUT4,OUT8 TSD / OC
 (0b 000 01000)

Data2 = 0x59 => OUT1 : Off (01)
 (0b 01 01 10 01) OUT2 : ON (10)
 OUT3 : Off (01)
 OUT4 : Off (01)

Data3 = 0xDA => OUT5 : ON (10)
 (0b 11 01 10 10) OUT6 : ON (10)
 OUT7 : Off (01)
 OUT8 : Off (11) Latched Off due to TSD/OC

**Note the placement of the bits for LSB and MSB!
 It is not intuitive. LSB is sent first.**

Table 20. GET STATUS EXAMPLE HEX RESPONSE

| Status | Hex Response | | OUT Number | | | | |
|--------|--------------|-----|------------|----|----|----|-----|
| | | | 1 | 2 | 3 | 4 | |
| OUT1-4 | 0x59 | LSB | 10 | 01 | 10 | 10 | MSB |
| OUT5-8 | 0xDA | LSB | 01 | 01 | 10 | 11 | MSB |

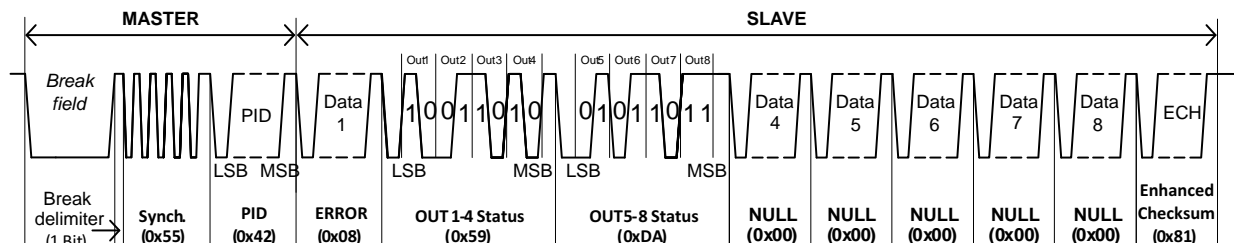

Figure 12. Example of Waveform of Get Status Command

GET NODE ID COMMAND

Table 21. GET NODE ID

| | Byte | Content | Structure | | | | | | | |
|--------|------|------------|------------------------------|-------|-------|---------|-------|-------|-------|-------|
| | | | Bit 7 | Bit 6 | Bit 5 | Bit 4 | Bit 3 | Bit 2 | Bit 1 | Bit 0 |
| Master | 0 | Identifier | PID | | | | | | | |
| Slave | 1 | Data 1 | ERR2 | ERR1 | ERR0 | APPINFO | | | | |
| | 2 | Data 2 | Index Byte (0x00) | | | | | | | |
| | 3 | Data 3 | Supplier ID, MSB (0x00) | | | | | | | |
| | 4 | Data 4 | Supplier ID, LSB (0x24) | | | | | | | |
| | 5 | Data 5 | Function ID, MSB (0x60) | | | | | | | |
| | 6 | Data 6 | Function ID, LSB (0x48/0x44) | | | | | | | |
| | 7 | Data 7 | Silicon Version | | | | | | | |
| | 8 | Data 8 | 0x00 (null) | | | | | | | |
| | 9 | Checksum | Enhanced Checksum | | | | | | | |

The Get Node ID Request frame (see Table 21) is issued by the master to receive Supplier ID and Function ID information. (Only prime node responds)

Data 1 is the same as in the Get status command. The mapping of the ID to be used based on NAD is shown in Table 23.

The Index byte is fixed to zero as the NCV7748 sends out only six bytes of part number data.

The Supplier ID for ON Semiconductor (Data3, 4) is 0x0024.

Table 22 shows the function ID assignment for the NCV7748.

Table 23. GET NODE ID / PID MAPPING

| R _{NAD} | NAD | ID | PID |
|------------------|------|------|------|
| 475 Ω | 0x60 | 0x00 | 0x80 |
| 1.00 kΩ | 0x62 | 0x08 | 0x08 |
| 2.21 kΩ | 0x64 | 0x10 | 0x50 |
| 4.75 kΩ | 0x66 | 0x18 | 0xD8 |
| 10.0 kΩ | 0x68 | 0x20 | 0x20 |
| 22.1 kΩ | 0x6A | 0x28 | 0xA8 |
| 47.5 kΩ | 0x6C | 0x30 | 0xF0 |

Table 22. FUNCTION ID ASSIGNMENT

| | Function ID, MSB | | Function ID, LSB | |
|---------|------------------|-----------|------------------|---|
| | Group | Sub-group | Part Number | |
| NCV7748 | 6 | 0 | 4 | 8 |

NCV7748

Table 24 shows get status ID to NAD and node position within virtual node in context of the SAEJ2602 spec.

Table 24. GET NODE ID COMMAND MAPPING LINKED TO SAEJ2602 SPEC

| NAD | Message ID | PID | NAD | Message ID | PID | NAD | Message ID | PID | NAD | Message ID | PID |
|------|------------|------|------|------------|------|------|------------|------|------|------------------------------|------|
| \$60 | \$0 | 0x80 | \$64 | \$10 | 0x50 | \$68 | \$20 | 0x20 | \$6C | \$30 | 0xF0 |
| | \$1 | | | \$11 | | | \$21 | | | \$31 | |
| | \$2 | | | \$12 | | | \$22 | | | \$32 | |
| | \$3 | | | \$13 | | | \$23 | | | \$33 | |
| | \$4 | | | \$14 | | | \$24 | | | \$34 | |
| | \$5 | | | \$15 | | | \$25 | | | \$35 | |
| | \$6 | | | \$16 | | | \$26 | | | \$36 | |
| | \$7 | | | \$17 | | | \$27 | | | \$37 | |
| \$62 | \$8 | 0x08 | \$66 | \$18 | 0xD8 | \$6A | \$28 | 0xA8 | \$6E | No Message IDs defined | |
| | \$9 | | | \$19 | | | \$29 | | | | |
| | \$0A | | | \$1A | | | \$2A | | | | |
| | \$0B | | | \$1B | | | \$2B | | | | |
| | \$0C | | | \$1C | | | \$2C | | \$6F | No Message IDs defined | |
| | \$0D | | | \$1D | | | \$2D | | | | |
| | \$0E | | | \$1E | | | \$2E | | | | |
| | \$0F | | | \$1F | | | \$2F | | | | |

READ BY IDENTIFIER COMMAND

Table 25. READ BY IDENTIFIER

| | Byte | Content | Structure | | | | | | | |
|--------|------|------------|--|-------|-------|-----------|-------|-------|-------|-------|
| | | | Bit 7 | Bit 6 | Bit 5 | Bit 4 | Bit 3 | Bit 2 | Bit 1 | Bit 0 |
| Master | 0 | Identifier | 0x00 (Parity) | | | 0x3C (ID) | | | | |
| | 1 | Data 1 | NAD or 0x7F (Wildcard NAD) | | | | | | | |
| | 2 | Data 2 | 0x06 (PCI) | | | | | | | |
| | 3 | Data 3 | 0xB2 (SID) | | | | | | | |
| | 4 | Data 4 | Node Identifier (see Node Identification Table 28) | | | | | | | |
| | 5 | Data 5 | Supplier ID LSB (0x24) or 0xFF (Wildcard Supplier ID) | | | | | | | |
| | 6 | Data 6 | Supplier ID MSB (0x00) or 0x7F (Wildcard Supplier ID) | | | | | | | |
| | 7 | Data 7 | Function ID LSB (0x48/0x44) or 0xFF (Wildcard Function ID) | | | | | | | |
| | 8 | Data 8 | Function ID MSB (0x60) or 0xFF (Wildcard Function ID) | | | | | | | |
| | 9 | Checksum | Classic Checksum | | | | | | | |

Table 26. POSITIVE RESPONSE FOR READ BY IDENTIFIER

| | Byte | Content | Structure | | | | | | | |
|--------|------|------------|-----------------------------|-------|-------|-----------|-------|-------|-------|-------|
| | | | Bit 7 | Bit 6 | Bit 5 | Bit 4 | Bit 3 | Bit 2 | Bit 1 | Bit 0 |
| Master | 0 | Identifier | 0x01 (Parity) | | | 0x3D (ID) | | | | |
| Slave | 1 | Data 1 | NAD | | | | | | | |
| | 2 | Data 2 | 0x06 (PCI) | | | | | | | |
| | 3 | Data 3 | 0xF2 (RSID) | | | | | | | |
| | 4 | Data 4 | Supplier ID LSB (0x24) | | | | | | | |
| | 5 | Data 5 | Supplier ID MSB (0x00) | | | | | | | |
| | 6 | Data 6 | Function ID LSB (0x48/0x44) | | | | | | | |
| | 7 | Data 7 | Function ID MSB (0x60) | | | | | | | |
| | 8 | Data 8 | Silicon Version | | | | | | | |
| | 9 | Checksum | Classic Checksum | | | | | | | |

Table 27. NEGATIVE RESPONSE FOR READ BY IDENTIFIER

| | Byte | Content | Structure | | | | | | | |
|--------|------|------------|----------------------|-------|-------|-----------|-------|-------|-------|-------|
| | | | Bit 7 | Bit 6 | Bit 5 | Bit 4 | Bit 3 | Bit 2 | Bit 1 | Bit 0 |
| Master | 0 | Identifier | 0x01 (Parity) | | | 0x3D (ID) | | | | |
| Slave | 1 | Data 1 | NAD | | | | | | | |
| | 2 | Data 2 | 0x03 (PCI) | | | | | | | |
| | 3 | Data 3 | 0x7F (RSID) | | | | | | | |
| | 4 | Data 4 | 0xB2 (Requested SID) | | | | | | | |
| | 5 | Data 5 | 0x12 (Error Code) | | | | | | | |
| | 6 | Data 6 | 0xFF | | | | | | | |
| | 7 | Data 7 | 0xFF | | | | | | | |
| | 8 | Data 8 | 0xFF | | | | | | | |
| | 9 | Checksum | Classic Checksum | | | | | | | |

The Read by Identifier Request frame (see Table 25) is issued by the master to receive application specific diagnostics.

Data1 (NAD selection) is explained previously (See Table 6 and Table 7). Data 4 (Node identifier) determines which of the nodes in the virtual LIN node should respond. (See Table 28). The identification of nodes within the virtual node is defined in Table 7.

If the Node identifier is in accordance with Table 28, the addressed slave answers by the Positive response (see Table 26). If the Identifier is out of range in Table 28 (not equal to 0x00, 0x20, 0x21, 0x22 or 0x23), the prime slave answers with the Negative response (see Table 27). A prime

device can be addressed by either the 0x00 (') identifier or the identifier associated with its letter designator (A, B, C, D).

An example of Read by Identifier request / response is shown below.

Table 28. NODE IDENTIFICATION

| Identifier | Responding Slave |
|------------|-----------------------|
| 0x00 | Prime (Marked with ') |
| 0x20 | A |
| 0x21 | B |
| 0x22 | C |
| 0x23 | D |

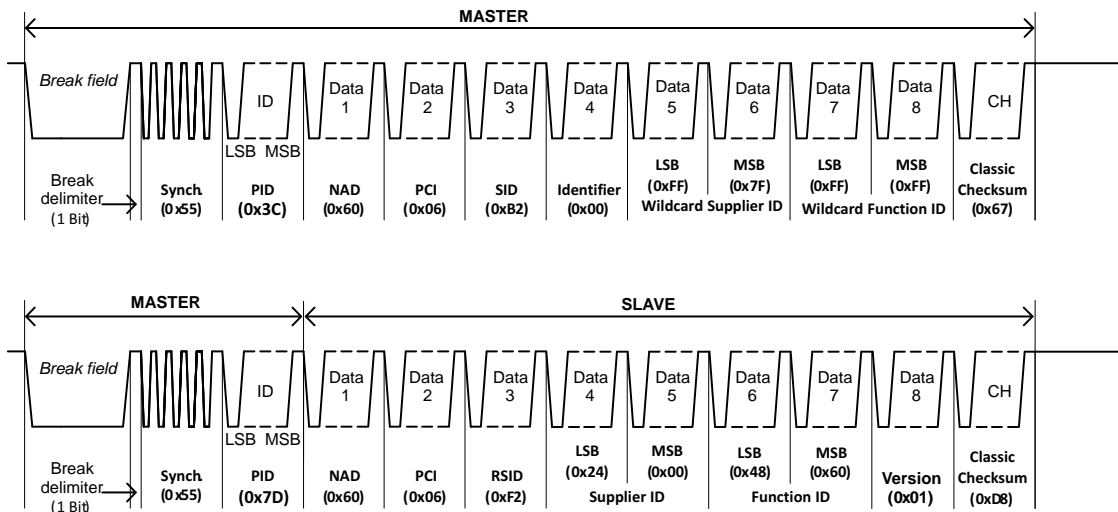

Figure 13. Example of Read by Identifier, NAD = 0x60, Prime Slave Addressed and Positive Responding

BROADCAST RESET COMMAND

Table 29. BROADCAST RESET FRAME

| | Byte | Content | Structure | | | | | | | |
|--------|----------|------------------|---------------|-------|-------|-------|-----------|-------|-------|-------|
| | | | Bit 7 | Bit 6 | Bit 5 | Bit 4 | Bit 3 | Bit 2 | Bit 1 | Bit 0 |
| Master | 0 | Identifier | 0x00 (Parity) | | | | 0x3C (ID) | | | |
| | 1 | Data 1 | 0x7F | | | | | | | |
| | 2 | Data 2 | 0x01 | | | | | | | |
| | 3 | Data 3 | 0xB5 | | | | | | | |
| | 4 | Data 4 | 0xFF | | | | | | | |
| | 5 | Data 5 | 0xFF | | | | | | | |
| | 6 | Data 6 | 0xFF | | | | | | | |
| | 7 | Data 7 | 0xFF | | | | | | | |
| | 8 | Data 8 | 0xFF | | | | | | | |
| 9 | Checksum | Classic Checksum | | | | | | | | |

Table 29 describes the command to reset all nodes. No slave response.

TARGETED RESET COMMAND

Table 30. TARGETED RESET REQUEST COMMAND

| | Byte | Content | Structure | | | | | | | |
|--------|----------|------------------|---------------|-------|-------|-----------|-------|-------|-------|-------|
| | | | Bit 7 | Bit 6 | Bit 5 | Bit 4 | Bit 3 | Bit 2 | Bit 1 | Bit 0 |
| Master | 0 | Identifier | 0x00 (Parity) | | | 0x3C (ID) | | | | |
| | 1 | Data 1 | NAD | | | | | | | |
| | 2 | Data 2 | 0x01 | | | | | | | |
| | 3 | Data 3 | 0xB5 | | | | | | | |
| | 4 | Data 4 | 0xFF | | | | | | | |
| | 5 | Data 5 | 0xFF | | | | | | | |
| | 6 | Data 6 | 0xFF | | | | | | | |
| | 7 | Data 7 | 0xFF | | | | | | | |
| | 8 | Data 8 | 0xFF | | | | | | | |
| 9 | Checksum | Classic Checksum | | | | | | | | |

Table 31. TARGETED RESET POSITIVE RESPONSE

| | Byte | Content | Structure | | | | | | | |
|--------|------|------------|-----------------------------|-------|-------|-----------|-------|-------|-------|-------|
| | | | Bit 7 | Bit 6 | Bit 5 | Bit 4 | Bit 3 | Bit 2 | Bit 1 | Bit 0 |
| Master | 0 | Identifier | 0x01 (Parity) | | | 0x3D (ID) | | | | |
| Slave | 1 | Data 1 | NAD | | | | | | | |
| | 2 | Data 2 | 0x06 | | | | | | | |
| | 3 | Data 3 | 0xF5 | | | | | | | |
| | 4 | Data 4 | Supplier ID LSB (0x24) | | | | | | | |
| | 5 | Data 5 | Supplier ID MSB (0x00) | | | | | | | |
| | 6 | Data 6 | Function ID LSB (0x48/0x44) | | | | | | | |
| | 7 | Data 7 | Function ID MSB (0x60) | | | | | | | |
| | 8 | Data 8 | Silicon Version | | | | | | | |
| | 9 | Checksum | Classic Checksum | | | | | | | |

Targeted reset (See Table 30) puts all the outputs into the off state (Table 11, OUTx Off), resets the error flags ERR.1,2 and sets the ERR.0 =1 in the ERR status byte (Table 15).

Targeted reset puts all outputs for all devices in a virtual node in the off state.

The node giving positive response (prime node) within the virtual node is defined by Table 31.

GO TO SLEEP COMMAND

Table 32. GO TO SLEEP COMMAND

| | Byte | Content | Structure | | | | | | | |
|--------|----------|------------------|---------------|-------|-------|-----------|-------|-------|-------|-------|
| | | | Bit 7 | Bit 6 | Bit 5 | Bit 4 | Bit 3 | Bit 2 | Bit 1 | Bit 0 |
| Master | 0 | Identifier | 0x00 (Parity) | | | 0x3C (ID) | | | | |
| | 1 | Data 1 | 0x00 | | | | | | | |
| | 2 | Data 2 | 0xFF | | | | | | | |
| | 3 | Data 3 | 0xFF | | | | | | | |
| | 4 | Data 4 | 0xFF | | | | | | | |
| | 5 | Data 5 | 0xFF | | | | | | | |
| | 6 | Data 6 | 0xFF | | | | | | | |
| | 7 | Data 7 | 0xFF | | | | | | | |
| | 8 | Data 8 | 0xFF | | | | | | | |
| 9 | Checksum | Classic Checksum | | | | | | | | |

The Go to sleep command (see Table 32) deactivates all the drivers and puts all the slave nodes connected to the LIN bus into the Sleep mode. In 0xFF, FF stands for don't care.

Output Driver Fault Handling

A summary of output driver device performance under fault conditions is summarized below. This includes reporting to the APPINFO register, the driver condition both during and after fault conditions, and what is required to clear reported faults.

Table 33. FAULT HANDLING

| Fault | APPINFO Register | OUTPUT Register | Drivers Condition during Fault | Drivers Condition after Parameters within Specified Limits | Output Register clearing Requirement | APPINFO Register Clearing Requirement |
|--|--------------------------------------|---|---|--|--|--|
| Open load (OUT4 and OUT8) | Not signaled. | Signaled in OFF Mode | Per setting | Driver in Normal operation | Load re-connected | NA |
| Overcurrent | Latched | latched | Affected driver turns off after T_OC_det time | Affected driver is latched off | Command OFF the affected driver | Command OFF the affected driver (OUT4 and OUT8) |
| Local Thermal Shutdown (OUT4 and OUT8) | Latched + masked low when Global TSD | latched | All driver turns off | Affected driver is latched off | Exit Local TSD Command OFF the affected driver (OUT4 and OUT8) | Exit Local TSD Command OFF the affected driver (OUT4 and OUT8) |
| Global Thermal Shutdown (TSD) | Not latched | Signaled | All drivers switched OFF | Returns to the previous programmed state | Exit Global TSD | Exit Global TSD |
| Undervoltage | NA | Register is not accessible as LIN is disabled | Per Setting (Change of state not possible as LIN is disabled) | Driver in Normal operation | NA | NA |

Table 34. FAULT REPORTING

| Fault | Drivers | |
|-----------------------------|-----------------|------------------|
| | OUT1-3, 5-7 | OUT4, 8 |
| Open Load (OFF state) | No | Yes |
| Overcurrent (ON state) | Yes (0.6 A min) | Yes (0.75 A min) |
| Individual Over Temperature | No | Yes |

1S0P Thermal Performance

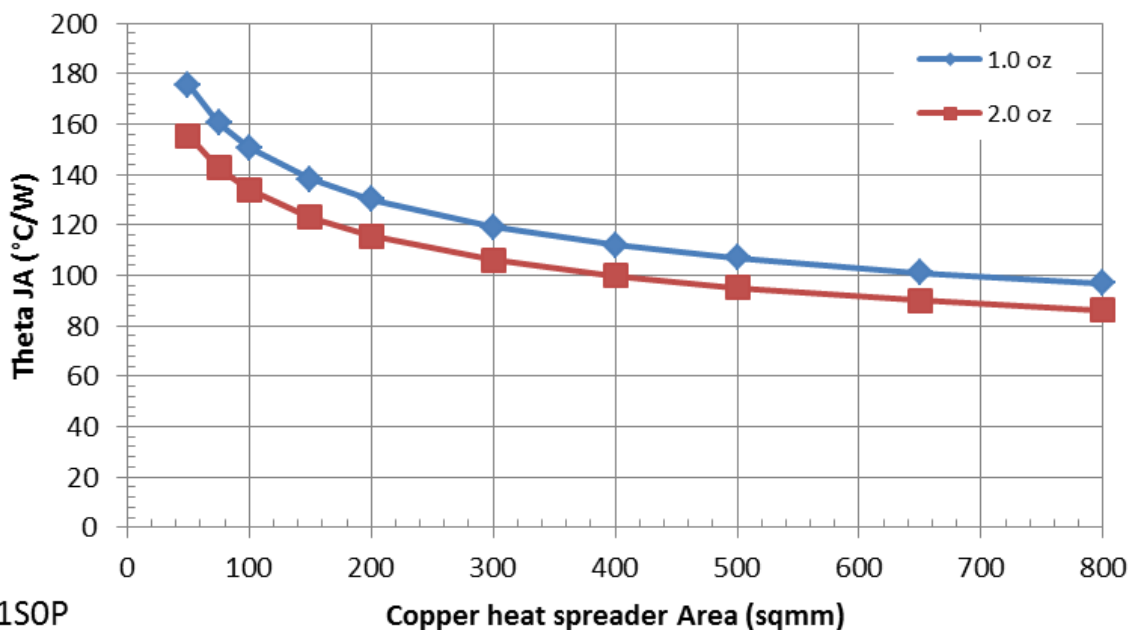

Figure 14. SOIC-14 θ_{JA} (1s0p) Copper Spreader Area

NCV7748

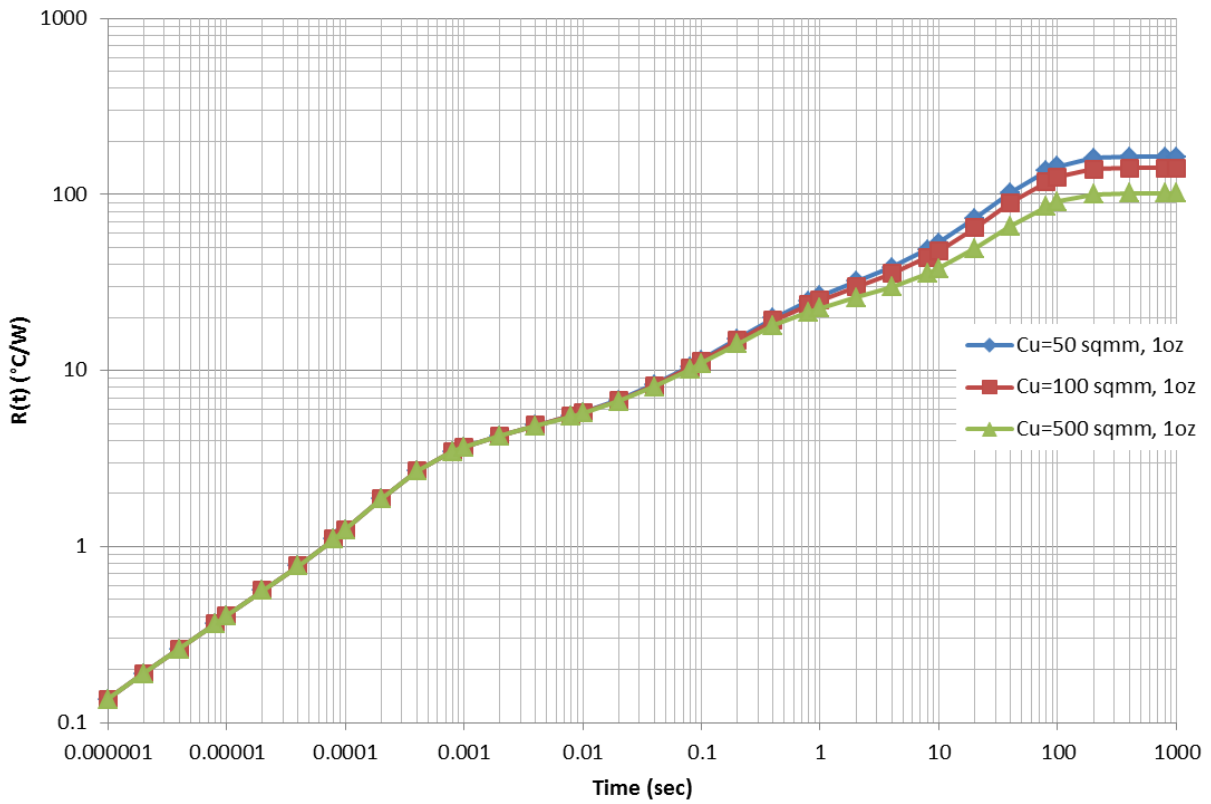

Figure 15. SOIC-14 Single Pulse Heating Curve (1s0p)

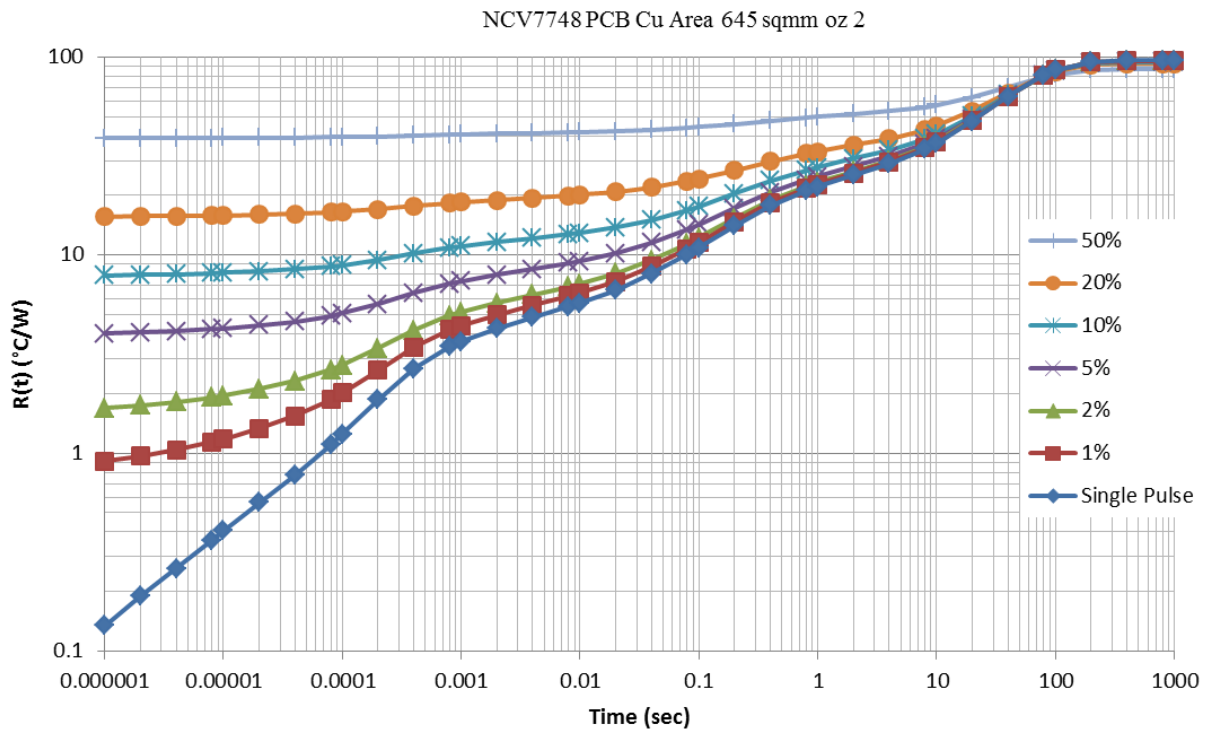
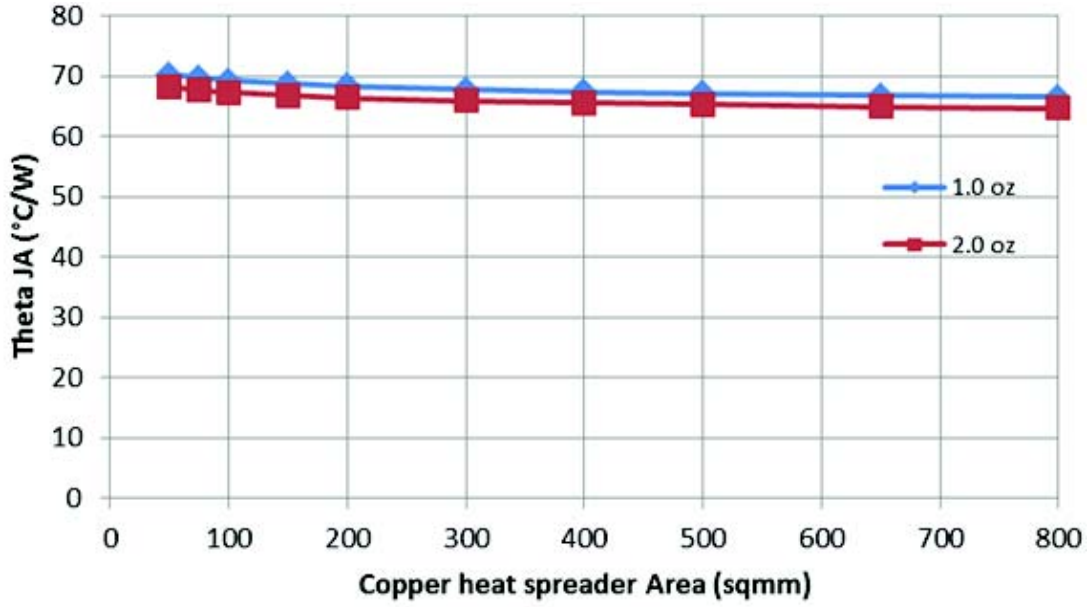

Figure 16. SOIC-14 Thermal Duty Cycle Curve on 645 mm² Spreader Test Board (1s0p)

2S2P Thermal Performance



2s2p

Figure 17. SOIC-14 θ_{JA} (2s2p) Copper Spreader Area

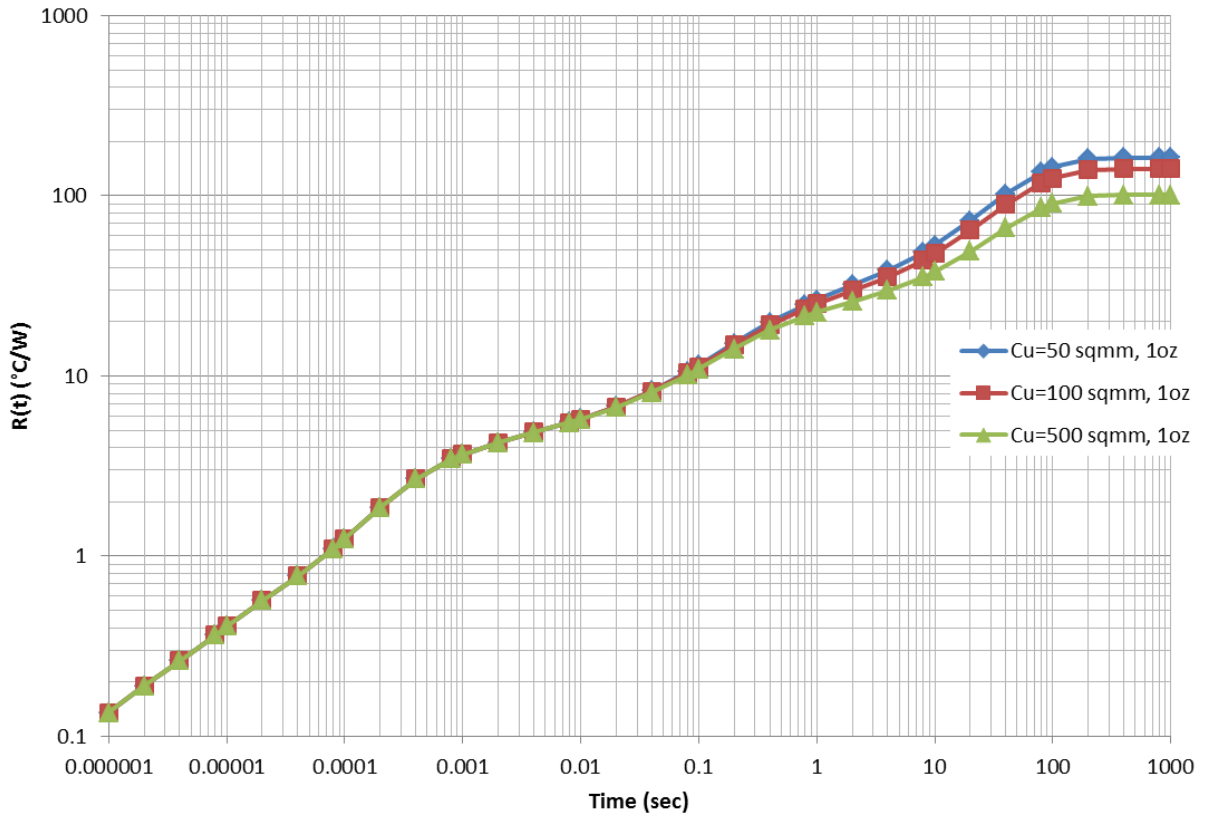

Figure 18. SOIC-14 Single Pulse Heating Curve (2s2p)

NCV7748

NCV7748 PCB Cu Area 6400 sqmm oz 2

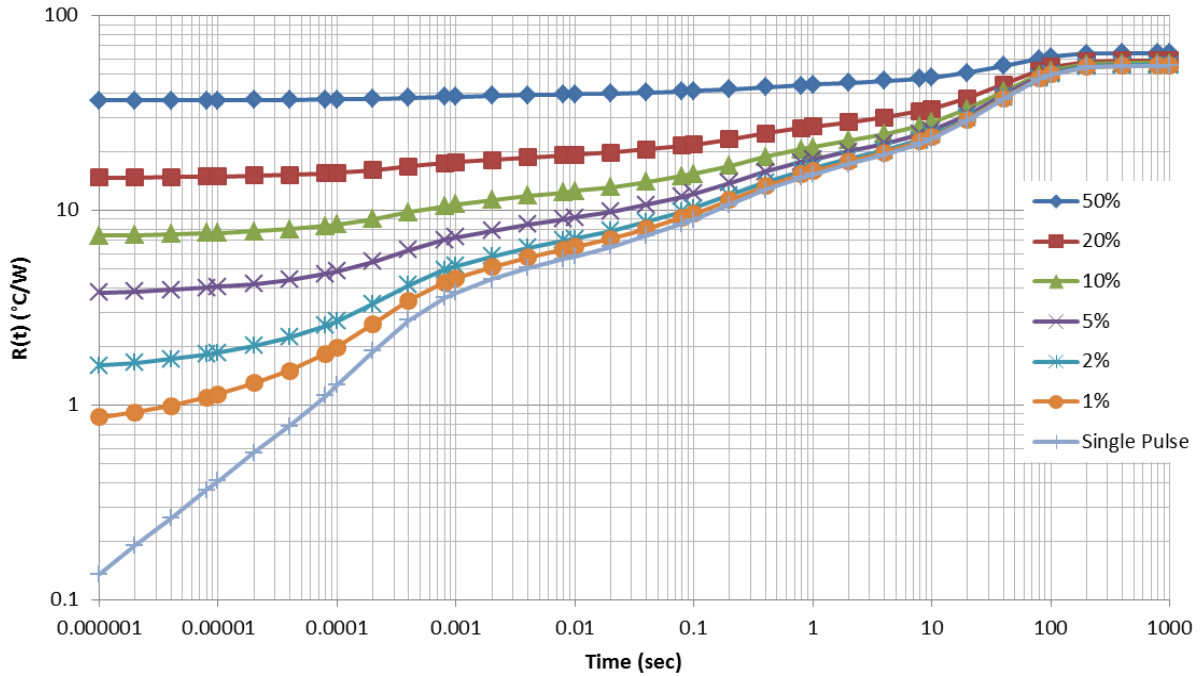

Figure 19. SOIC-14 Thermal Duty Cycle Curve on 645 mm² Spreader Test Board (2s2p)

ORDERING INFORMATION

| Device Order Number | Number of Channels | Package | Shipping [†] |
|---------------------|--------------------|----------------------|-----------------------|
| NCV7748D2R2G | 8 | SOIC-14 (Pb-Free) | 2500 / Tape & Reel |

[†]For information on tape and reel specifications, including part orientation and tape sizes, please refer to our Tape and Reel Packaging Specifications Brochure, BRD8011/D.

NCV7748

PACKAGE DIMENSIONS

SOIC-14 NB CASE 751A ISSUE L

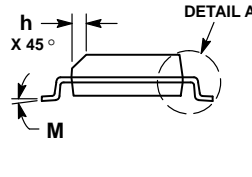
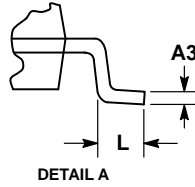
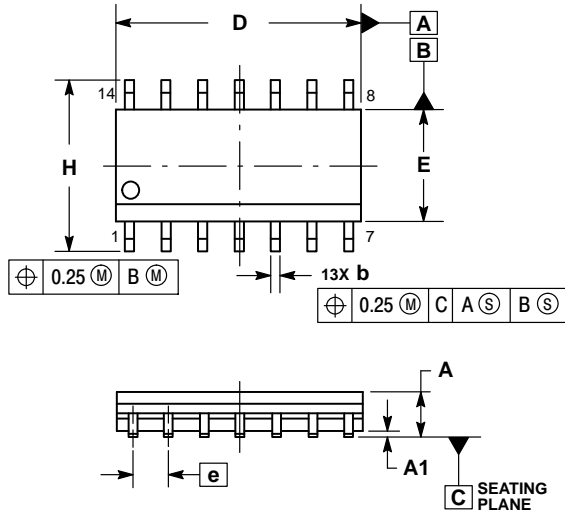

NOTES:

1. DIMENSIONING AND TOLERANCING PER ASME Y14.5M, 1994.
2. CONTROLLING DIMENSION: MILLIMETERS.
3. DIMENSION b DOES NOT INCLUDE DAMBAR PROTRUSION. ALLOWABLE PROTRUSION SHALL BE 0.13 TOTAL IN EXCESS OF AT MAXIMUM MATERIAL CONDITION.
4. DIMENSIONS D AND E DO NOT INCLUDE MOLD PROTRUSIONS.
5. MAXIMUM MOLD PROTRUSION 0.15 PER SIDE.

| DIM | MILLIMETERS | | INCHES | |
|-----|-------------|------|-----------|-------|
| | MIN | MAX | MIN | MAX |
| A | 1.35 | 1.75 | 0.054 | 0.068 |
| A1 | 0.10 | 0.25 | 0.004 | 0.010 |
| A3 | 0.19 | 0.25 | 0.008 | 0.010 |
| b | 0.35 | 0.49 | 0.014 | 0.019 |
| D | 8.55 | 8.75 | 0.337 | 0.344 |
| E | 3.80 | 4.00 | 0.150 | 0.157 |
| e | 1.27 BSC | | 0.050 BSC | |
| H | 5.80 | 6.20 | 0.228 | 0.244 |
| h | 0.25 | 0.50 | 0.010 | 0.019 |
| L | 0.40 | 1.25 | 0.016 | 0.049 |
| M | 0° | 7° | 0° | 7° |

SOLDERING FOOTPRINT*

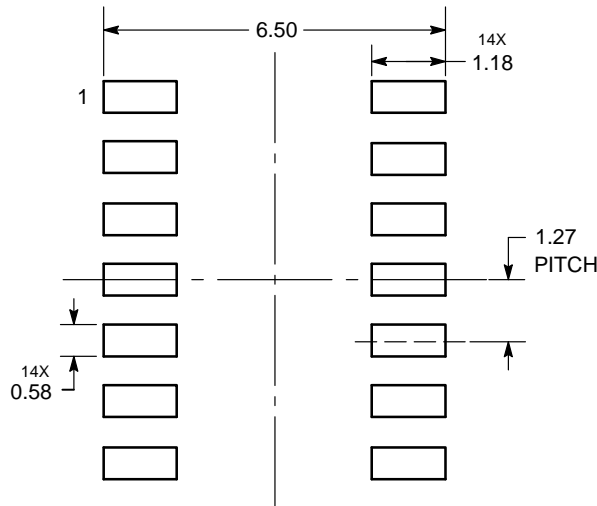

DIMENSIONS: MILLIMETERS

*For additional information on our Pb-Free strategy and soldering details, please download the ON Semiconductor Soldering and Mounting Techniques Reference Manual, SOLDERRM/D.

ON Semiconductor and are trademarks of Semiconductor Components Industries, LLC dba ON Semiconductor or its subsidiaries in the United States and/or other countries. ON Semiconductor owns the rights to a number of patents, trademarks, copyrights, trade secrets, and other intellectual property. A listing of ON Semiconductor's product/patent coverage may be accessed at www.onsemi.com/site/pdf/Patent-Marketing.pdf. ON Semiconductor reserves the right to make changes without further notice to any products herein. ON Semiconductor makes no warranty, representation or guarantee regarding the suitability of its products for any particular purpose, nor does ON Semiconductor assume any liability arising out of the application or use of any product or circuit, and specifically disclaims any and all liability, including without limitation special, consequential or incidental damages. Buyer is responsible for its products and applications using ON Semiconductor products, including compliance with all laws, regulations and safety requirements or standards, regardless of any support or applications information provided by ON Semiconductor. "Typical" parameters which may be provided in ON Semiconductor data sheets and/or specifications can and do vary in different applications and actual performance may vary over time. All operating parameters, including "Typicals" must be validated for each customer application by customer's technical experts. ON Semiconductor does not convey any license under its patent rights nor the rights of others. ON Semiconductor products are not designed, intended, or authorized for use as a critical component in life support systems or any FDA Class 3 medical devices or medical devices with a same or similar classification in a foreign jurisdiction or any devices intended for implantation in the human body. Should Buyer purchase or use ON Semiconductor products for any such unintended or unauthorized application, Buyer shall indemnify and hold ON Semiconductor and its officers, employees, subsidiaries, affiliates, and distributors harmless against all claims, costs, damages, and expenses, and reasonable attorney fees arising out of, directly or indirectly, any claim of personal injury or death associated with such unintended or unauthorized use, even if such claim alleges that ON Semiconductor was negligent regarding the design or manufacture of the part. ON Semiconductor is an Equal Opportunity/Affirmative Action Employer. This literature is subject to all applicable copyright laws and is not for resale in any manner.

PUBLICATION ORDERING INFORMATION

LITERATURE FULFILLMENT:
Literature Distribution Center for ON Semiconductor
19521 E. 32nd Pkwy, Aurora, Colorado 80011 USA
Phone: 303-675-2175 or 800-344-3860 Toll Free USA/Canada
Fax: 303-675-2176 or 800-344-3867 Toll Free USA/Canada
Email: orderlit@onsemi.com

N. American Technical Support: 800-282-9855 Toll Free
USA/Canada
Europe, Middle East and Africa Technical Support:
Phone: 421 33 790 2910
Japan Customer Focus Center
Phone: 81-3-5817-1050

ON Semiconductor Website: www.onsemi.com
Order Literature: <http://www.onsemi.com/orderlit>

For additional information, please contact your local Sales Representative