

CFT2

Terminal Pins : Straight
Actuator Color : Gray

Washable

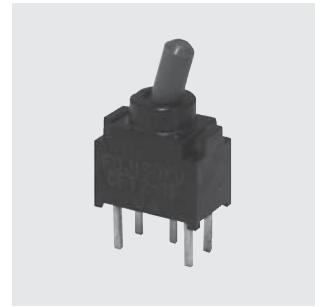

Ultra-Miniature Toggle Switch

RoHS Compliant

Features

1. Ultra-miniature toggle switch for high density mounting.
2. Washable.
3. Terminal pin pitch: 2.54 mm.
4. Independent detent mechanism ensures light operational feel.
5. Clip contact mechanism for long-term contact reliability.
6. Gold-plated contacts.

Specifications

Rating	Max.	28VDC 0.4VA max.
	Min.	1μ A 20mVDC
Initial contact resistance	100mΩ max. (1.5mA 200μVAC)	
Dielectric strength	250VAC 1 minute	
Insulation resistance	500MΩ min. (250VDC)	
Electrical life	10,000 cycles at max. rating. 50,000 cycles at min. rating. (D.E.N.P type) 30,000 cycles at min. rating. (F.G.H.R.S.T type)	
Mechanical life	D.E.N.P type 50,000 cycles F.G.H.R.S.T type 30,000 cycles	
Operating temperature range	-40°C~+85°C	
Storage temperature range	-40°C~+85°C	

Part Numbering

CFT2 - **2** **N** **C4** - **A** **W**

Series Actuator

Number of poles

Switching function

Terminal style

Actuator shape

Packaging spec

Code	Type
T	Toggle

Fig.	Number of poles
1	1 pole
2	2 poles

1 pole	2 poles	Switching function
D	N	ON - ON
E	P	ON-OFF-ON
F	R	ON - (ON)
G	S	(ON)-OFF-(ON)
H	T	ON-OFF-(ON)

Fig.	Terminal style
C	PC Straight
C4	Right angle
C6	Vertical mounting

Code	Actuator shape
A	Standard

Code	Packaging spec
W	Tray

Terminal style of c (Style : PC Terminal)	Terminal style of c4 (Style : R/A Terminal)	Terminal style of c6 (Style : V/M Terminal)

(ON) : Momentary.

CFT2

SPDT

PC Straight

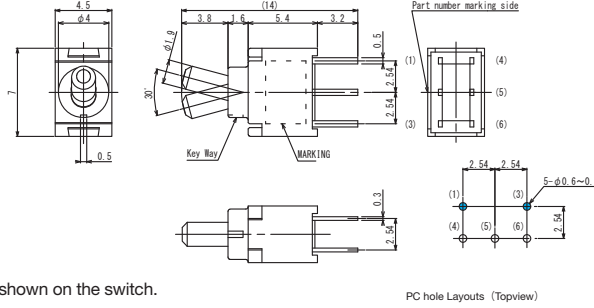

Terminal numbers are not shown on the switch.

PC hole Layouts (Topview)

Switching function			
Part No.			
CFT2-1DC-AW	ON	—	ON
CFT2-1EC-AW	ON	OFF	ON
☆ CFT2-1FC-AW	ON	—	(ON)
☆ CFT2-1GC-AW	(ON)	OFF	(ON)
☆ CFT2-1HC-AW	ON	OFF	(ON)
Connecting terminals	5—6	—	5—4

DPDT

PC Straight

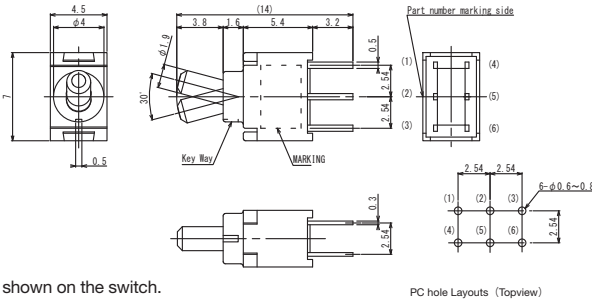

Terminal numbers are not shown on the switch.

PC hole Layouts (Topview)

Switching function			
Part No.			
☆ CFT2-2NC-AW	ON	—	ON
☆ CFT2-2PC-AW	ON	OFF	ON
☆ CFT2-2RC-AW	ON	—	(ON)
☆ CFT2-2SC-AW	(ON)	OFF	(ON)
☆ CFT2-2TC-AW	ON	OFF	(ON)
Connecting terminals	2—3 5—6	—	2—1 5—4

SPDT

Right Angle Terminal

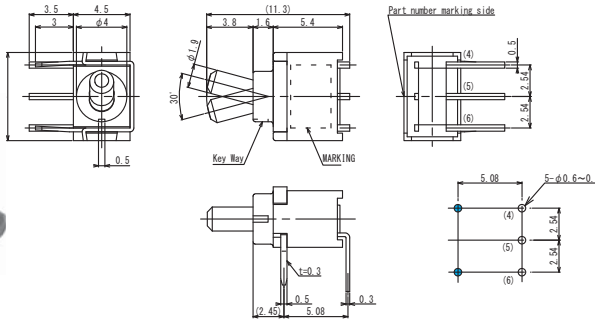
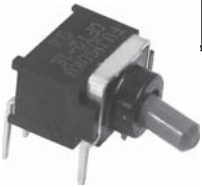

Terminal numbers are not shown on the switch.

PC hole Layouts (Topview)

Switching function			
Part No.			
CFT2-1DC4-AW	ON	—	ON
CFT2-1EC4-AW	ON	OFF	ON
☆ CFT2-1FC4-AW	ON	—	(ON)
☆ CFT2-1GC4-AW	(ON)	OFF	(ON)
☆ CFT2-1HC4-AW	ON	OFF	(ON)
Connecting terminals	5—6	—	5—4

DPDT

Right Angle Terminal

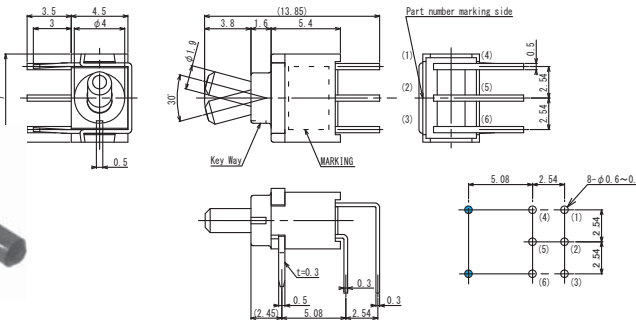

Terminal numbers are not shown on the switch.

PC hole Layouts (Topview)

Switching function			
Part No.			
☆ CFT2-2NC4-AW	ON	—	ON
☆ CFT2-2PC4-AW	ON	OFF	ON
☆ CFT2-2RC4-AW	ON	—	(ON)
☆ CFT2-2SC4-AW	(ON)	OFF	(ON)
☆ CFT2-2TC4-AW	ON	OFF	(ON)
Connecting terminals	2—3 5—6	—	2—1 5—4

CFT2

SPDT

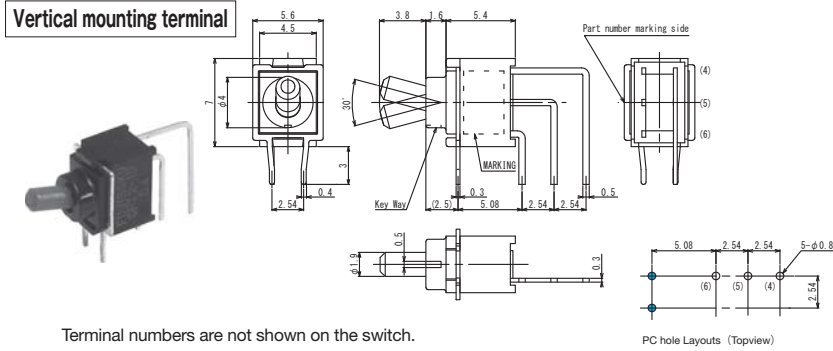

Switching function Part No.			
	CFT2-1DC6-AW	ON	—
CFT2-1EC6-AW	ON	OFF	ON
☆CFT2-1FC6-AW	ON	—	(ON)
☆CFT2-1GC6-AW	(ON)	OFF	(ON)
☆CFT2-1HC6-AW	ON	OFF	(ON)
Connecting terminals	5—6	—	4—5

DPDT

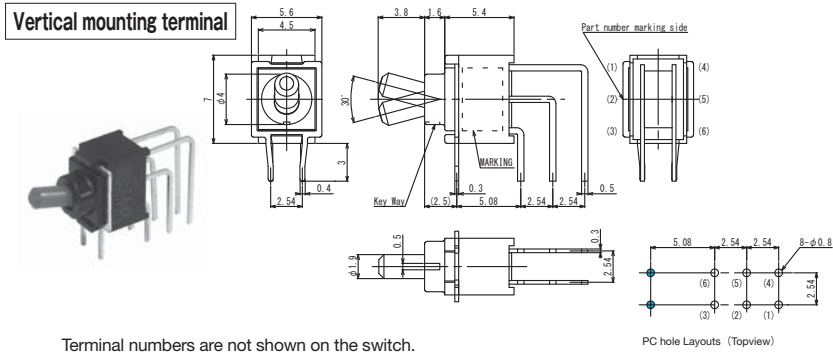

Switching function Part No.			
	☆CFT2-2NC6-AW	ON	—
☆CFT2-2PC6-AW	ON	OFF	ON
☆CFT2-2RC6-AW	ON	—	(ON)
☆CFT2-2SC6-AW	(ON)	OFF	(ON)
☆CFT2-2TC6-AW	ON	OFF	(ON)
Connecting terminals	2—3 5—6	—	1—2 4—5

■Soldering Specifications

(1)Manual Soldering

Device : Soldering iron
350°C, Max.; 3 seconds, Max.

(2)Auto Soldering

Device : Jet wave type or dip type
260°C, Max.; 3 to 5 seconds (One time)
Total dip time within 10 sec.

• Pre-heating should be done at temperatures ranging from 80°C to 120°C and within 120 sec.

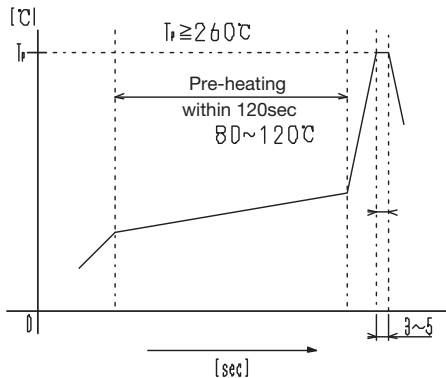

(3)When soldering two or more terminals to the common land, use the solder resist to solder them independently.

■Flux Cleaning

(1)Solvent : Fluorine or Alcohol type.

(2)Cleaning after soldering should be done after the PC board is exposed to room temperature (30°C or below) for 1 to 2 hours.

(3)Do not use ultrasonic cleaning.

■Packaging Specifications

